

INSTALLATION & OPERATING INSTRUCTIONS



Gas-Fired Pool & Spa Heater



**Atmospheric Models
268 & 408**



WARNING: If these instructions are not followed exactly, a fire or explosion may result causing property damage, personal injury or death.

Do not store or use gasoline or other flammable vapors and liquids in the vicinity of this or any other appliance.

WHAT TO DO IF YOU SMELL GAS:

- Do not try to light any appliance.
- Do not touch any electrical switch; do not use any phone in your building.
- Immediately call your gas supplier from a neighbor's phone. Follow the gas supplier's instructions.
- If you cannot reach your gas supplier, call the fire department.

Installation and service must be performed by a qualified installer, service agency or the gas supplier.

This manual should be maintained in legible condition and kept adjacent to the heater or in a safe place for future reference.

WATER CHEMISTRY
(Corrosive water voids all warranties)

For your health and the protection of your pool equipment, it is essential that your water be chemically balanced. The following levels must be used as a guide for balanced water.

Recommended Level(s)	Fiberglass Pools	Fiberglass Spas	Other Pool & Spa Types
Water Temp. (Deg. F)	68 to 88	89 to 104	68 to 104
pH	7.3 to 7.4	7.3 to 7.4	7.6 to 7.8
Total Alkalinity (PPM)	120 to 150	120 to 150	80 to 120
Calcium Hardness (PPM)	200 to 300	150 to 200	200 to 400
Salt (PPM)	4500 MAXIMUM	4500 MAXIMUM	4500 MAXIMUM
Free Chlorine (PPM)*	2 to 3	2 to 3	2 to 3
Total Dissolved Solids (PPM)	3000 MAXIMUM**	3000 MAXIMUM**	3000 MAXIMUM**

*** Free Chlorine MUST NOT EXCEED 5 PPM!**

** In salt water chlorinated pools, the total TDS can be as high as 6000 ppm.

- Occasional chemical shock dosing of the pool or spa water should not damage the heater providing the water is balanced.
- Automatic chemical dosing devices and salt chlorinators are usually more efficient in heated water, unless controlled, they can lead to excessive chlorine level **which can damage your heater, and which is not covered under warranty.**
- Further advice should be obtained from your pool or spa builder, accredited pool shop, or chemical supplier for the correct levels for your water.

CONTENTS

4	PART ONE		
	OWNER'S OPERATING INSTRUCTIONS		
4	SECTION 1		
	START-UP PROCEDURES		
4	Before Start-Up	21	Auxiliary Bypass Valve Adjustment
5	Operating Instruction & Shut-Off Procedures - Automatically Lighted Pilots IID	21	Pressure Relief Valve Installation
6	After Start-Up	22	Plumbing—Water Connections
6	SECTION 2	23	Electrical Wiring
	CAUTION	24	Transformer Wiring
7	SECTION 3	25	Wiring Diagram
	MAINTENANCE & CARE PROCEDURES	26	SECTION 4
7	Pool & Spa Water Chemistry		SERVICING INSTRUCTIONS
7	Automatic Chlorinators & Chemical Feeders	26	General Location of Controls
8	Cold Weather Operation	26	Control Panel Removal
8	Winterizing the Pool & Spa Heater	26	Control Adjustments
9	PART TWO	27	Thermostat Operation
	INSTALLATION & SERVICE INSTRUCTIONS	29	Status and Diagnostics
9	SECTION 1	30	Remote Control Installation and Operation
	RECEIVING EQUIPMENT	30	Remote Operation
10	SECTION 2	30	Activating the Remote
	GENERAL SPECIFICATIONS	31	Remote Control Wiring
10	SECTION 3	31	2-Wire Remote Control
	INSTALLATION INSTRUCTIONS	31	3-Wire Remote Control
10	Code Requirements	32	Time Clock / Fireman's Switch
11	Clearances	32	Water Flow Switch
11	Outdoor Heater Installation	32	Flame Roll-Out Safety Switch
13	Florida and Texas Building Codes	32	High Limits
14	Indoor Heater Installation	33	Pilot Safety
14	Outdoor Stack/Indoor Stack	33	Burner Tray Removal
15	Specifications and Dimensions	33	Gas Valve Removal
16	Combustion and Ventilation Air	33	Main Burner and Orifice Removal
16	Vent Piping	33	Pilot Removal and Cleaning
17	Gas Supply Connections	34	Heat Exchanger Removal
18	Gas Pressure Regulator	34	Tube Cleaning Procedure
18	Gas Pressure Adjustment Locations	34	Desooting Procedure
18	Pipe Sizing For Gas Connections	34	Combustion Chamber Removal
19	Flow Rates	34	Immersion Well Replacement
19	Heat Exchanger Pressure Drop	35	Unitherm Governor (U.G.) Replacement
20	Water Connection Installation	36	SECTION 5
20	Unitherm Governor Operation		TROUBLESHOOTING
21	Internal Automatic Bypass Valve	36	Mechanical
21	External Auxiliary Bypass Valve	37	Control Logic - Flow Chart
		38	SECTION 6
			REPLACEMENT PARTS
		39	Illustrated Parts List
		40	Part Numbers

PART ONE

OWNER'S OPERATING INSTRUCTIONS

FOR YOUR SAFETY - READ BEFORE OPERATING

WARNING: IF YOU DO NOT FOLLOW THESE INSTRUCTIONS EXACTLY, A FIRE OR EXPLOSION MAY RESULT, CAUSING PROPERTY DAMAGE, PERSONAL INJURY OR LOSS OF LIFE.

SECTION 1 - START-UP PROCEDURES

Your pool/spa heater has been designed for years of safe and reliable pool/spa water heating. It is available with electronic ignition. This manual provides installation, operation, maintenance, and service information for these heaters.

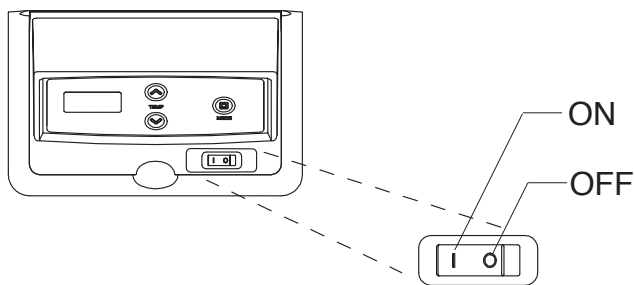

If your heater has been installed correctly, operating the heater is an easy task. The upper front panel of the heater contains the control center that allows you to turn the heater On or Off and adjust the temperature settings for the pool or spa. The temperature range is factory set from 65°F (18°C) to 104°F (40°C). See figure above for location of toggle switch to turn the heater On and Off. Section 4 of this manual contains more details about the use of the controls in the Control Adjustments subsection (page 26).

BEFORE START-UP

BURNERS

Clean main burners and air louvers of dust, lint and debris. Keep heater area clear and free from combustibles, flammable liquids and chemicals. Do not obstruct the flow of combustion and ventilation air.

WATER

Water must be flowing through the heater during operation. Ensure that the system is filled with water and that the pump is operating.

CAUTION: Propane gas is heavier than air and will settle on the ground. Since propane can accumulate in confined areas, extra care should be exercised when lighting propane heaters.

OPERATING INSTRUCTIONS AND SHUT-OFF PROCEDURES ELECTRONIC IGNITION SYSTEM (AUTOMATICALLY LIGHTED PILOT)

- A. This appliance is equipped with an ignition device which automatically lights the pilot. Do not try to light the pilot by hand.
- B. BEFORE OPERATING, smell all around the appliance area for gas. Be sure to smell near the floor because some gas is heavier than air and will settle on the floor.



WHAT TO DO IF YOU SMELL GAS:

- *Do not try to light any appliance.
- *Do not touch any electric switch; do not use any phone in your building.
- *Immediately call your gas supplier from a neighbor's phone. Follow the gas supplier's instructions.

*If you cannot reach your gas supplier, call the fire department.

- C. Use only your hand to push in or turn the gas control knob. Never use tools. If the knob will not push in or turn by hand, do not try to repair it. Call a qualified service technician. Force or attempted repair may result in a fire or explosion.
- D. Do not use this appliance if any part has been under water. Immediately call a qualified service technician to inspect the appliance and to replace any part of the control system and any gas control which has been under water.

OPERATING INSTRUCTIONS

1. **STOP!** Read the safety information above.
2. Set the thermostat to the lowest setting.
3. Turn off all electrical power to the appliance.
4. This appliance is equipped with an ignition device which automatically lights the pilot. Do not try to light the pilot by hand.
5. Remove heater door panel.
6. Turn gas control knob clockwise  to "Off". (Honeywell VR 8300 and Robertshaw 7000)
7. Wait 5 minutes to clear out any gas. If you then smell gas, **STOP!** Follow "B" in the safety information above. If you don't smell gas, go to the next step.
8. Turn gas control knob counter-clockwise  to "On". (Honeywell VR 8300 and Robertshaw 7000)
9. Replace heater door panel.
10. Turn on all electrical power to the appliance.
11. Set thermostat to desired setting.
12. If the appliance will not operate, follow the instructions "To Turn Off Gas To Appliance" and call your service technician or gas supplier.

HONEYWELL
VR 8300 GAS
VALVE IID

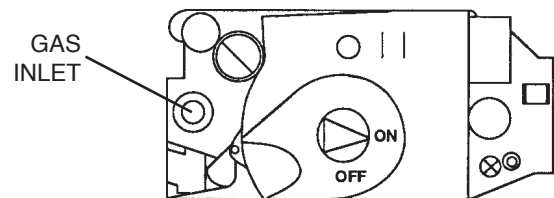

ROBERTSHAW 7000
GAS VALVE IID

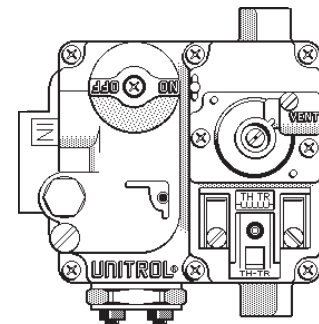

SHUT-OFF PROCEDURES

1. Set the thermostat at the lowest setting.
2. Turn off all the electrical power to the appliance if service is to be performed.
3. Remove heater door panel.
4. **For Honeywell VR 8300 and Robertshaw 7000 gas valve.** Turn gas control knob clockwise  to "Off". Make sure knob rest against stop.
5. Replace heater door panel.

AFTER START-UP

Feel the inlet and outlet pipes. Outlet pipe should be only slightly warmer than the inlet. It should not be hot.

WARNING: *Should overheating occur or the gas supply fail to shut off, turn off the manual gas control to the appliance.*

VISUAL INSPECTION - ATMOSPHERIC HEATERS

With the heater on, remove the door and make a visual check of the pilot and burner. The flame should be blue with a well-defined pattern.

A yellow or "floating" flame indicates restricted air openings or incorrect orifice size. Should this occur, shut the heater off and contact your installer or gas supplier.

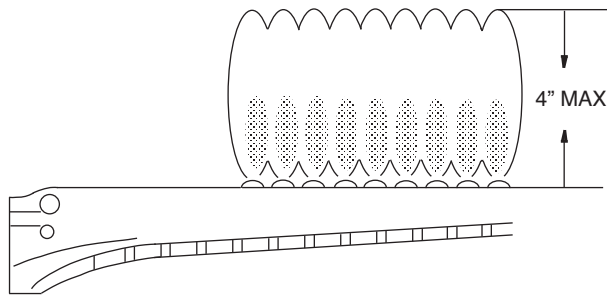

MAIN BURNER FLAME

WARNING: *Operation of the heater without water circulation will cause rapid and severe damage to the heater, and will void the warranty.*

SECTION 2 - CAUTION

Elevated water temperature can be hazardous. The U.S. Consumer Product Safety Commission has these guidelines:

1. Spa water temperatures should never exceed 104°F (40°C). A temperature of 100°F (38°C) is considered safe for a healthy adult. Special caution is suggested for young children.
2. Drinking of alcoholic beverages before or during spa or hot tub use can cause drowsiness which could lead to unconsciousness and subsequently result in drowning.
3. *Pregnant Women Beware!* Soaking in water over 102°F (39°C) can cause fetal damage during the first three months of pregnancy resulting in the birth of a brain-damaged or deformed child. Pregnant women should stick to the 100°F (38°C) maximum rule.
4. Before entering the spa or hot tub, users should check the water temperature with an accurate thermometer; spa or hot tub thermostats may err in regulating water temperatures by as much as 4°F (2.2°C).
5. Persons with a medical history of heart disease, circulatory problems, diabetes, or blood pressure problems should obtain a physician's advice before using pools or hot tubs.
6. Persons taking medications which induce drowsiness, such as tranquilizers, antihistamines, or anti-coagulants, should not use spas or hot tubs.

SECTION 3 - MAINTENANCE AND CARE PROCEDURES

WARNING: *Check the heater for possible rodent nests after long periods of non-use.*

To be followed one month after start-up and then semi-annually.

1. Inspect top of heater and draft hood for soot, a sticky black substance around finned tubes and "V" baffles, and open flue gas passageways. Any visible soot should be cleaned for proper operation.

CAUTION: *Soot may be combustible. Wet sooted surfaces completely prior to cleaning. Do not use steel wire brush.*

2. Clean main burners and pilot burner of dust and lint.
3. Inspect and operate all controls, gas valve and pressure relief valve (if equipped).
4. Make visual check of the burner and pilot flames. Flame pattern on the main burner and pilot is illustrated on page 6. Yellow flame means restriction of the air openings. Lifting or blowing flame indicates high gas pressure. Low flame means low gas pressure. Should the latter occur, shut the heater off and contact your gas supplier or qualified service agency.
5. On indoor heaters, clean room intake openings to ensure adequate flow of combustion and ventilation air.

CAUTION: *Combustion air must not be contaminated by corrosive chemical fumes which can damage the heater and void the warranty.*

6. Keep area around heater clear and free from combustible materials, gasoline and other flammable and corrosive vapors and liquids.

IF HEATER WILL NOT FIRE:

If you have no electrical power, it may be that your "circuit breaker" has tripped. Try re-setting it.

If you have electrical power but the heater will not fire check the following or see Troubleshooting section:

1. The time clock must be in the "ON" position.

2. Your pump strainer basket may be full. If so remove debris.
3. Your filter may be dirty. If so, backwash or clean filter. (To tell if your filter is dirty, look to see if the filter pressure will be higher than usual).
4. The pump may have lost its prime and be running dry. Check the pressure on the filter. If there is no pressure; then you are not moving water (or your gauge is broken). Try to get the pump to run at its normal flow rate.
5. Check flow switch operation and paddles ("F" paddle on 268 or "A" paddle on 408).

POOL & SPA WATER CHEMISTRY

Chemical imbalance can cause severe damage to your heater and associated equipment. Maintain your water chemistry according to the chart on page 2. If the mineral content and dissolved solids in the water become too high, scale forms inside the heat exchanger tubes, reducing heater efficiency and damaging the heater. If the pH drops below 7.2, this will cause corrosion of the heat exchanger and severely damage the heater. **Heat exchanger damage resulting from chemical imbalance is not covered by the warranty.**

AUTOMATIC CHLORINATORS AND CHEMICAL FEEDERS

All chemicals must be introduced and completely diluted into the pool or spa water before being circulated through the heater. Do not place sanitizing chemicals in the skimmer. High chemical concentrations will result when the pump is not running (e.g. overnight).

Chlorinators must feed downstream of the heater and have an anti-siphoning device to prevent chemical back-up into the heater when the pump is shut off.

See plumbing diagrams on page 22.

NOTE: *High chemical concentrates from feeders and chlorinators that are out of adjustment will cause rapid corrosion to the heat exchanger. Such damage is not covered under the warranty.*

COLD WEATHER OPERATION

IMPORTANT FREEZE INFORMATION

MODERATE CLIMATE: Heater operation can continue during short-term cold spells. When temperatures are between 0° and 32°F, flow (continuous pump operation) must be maintained.

CAUTION: Do not use the heater to maintain water temperatures just above freezing or for freeze protection. When heater is used during freezing weather, care must be taken to avoid freeze-ups. Continuous pump operation is a must. Additional protection may be required. The heater is not warranted against freeze-ups.

COLD CLIMATE: Prolonged operation with water temperatures below 50°F is not recommended. When starting the heater with water temperatures below 50°F, operate the heater continuously until higher temperatures are reached. Operating the heater for prolonged periods with pool water below 50°F can seriously damage the heater, and is not covered by the warranty.

For cold climate areas, please follow the winterizing procedures listed.

WINTERIZING THE POOL & SPA HEATER

Heaters installed outdoors in freezing climate areas may be shut down for the winter. Observe the following procedure for winterizing the heater:

1. Turn off gas valve, manual gas valve, and electrical supply to the heater.
2. Open drain valve located on the inlet/outlet header, (under water pipes). Remove the heat exchanger inspection panel on the side opposite water piping to gain access to the drain plug on the return header. Open drain plug on return header.

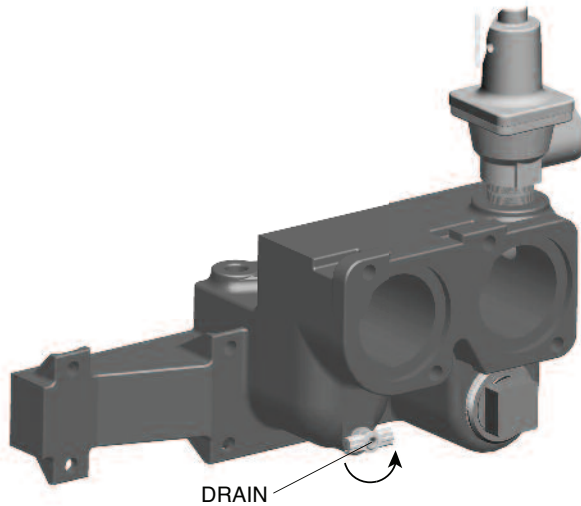

PART TWO INSTALLATION AND SERVICE INSTRUCTIONS

SECTION 1 - RECEIVING EQUIPMENT

INSTALLERS - The manufacturer recommends that this manual be reviewed thoroughly before installing the pool/spa heater. If there are any questions that this manual does not answer, please contact the factory or your local representative.

On receipt of your equipment it is suggested that you visually check for external damage to the carton. If the carton is damaged, a note should be made on the Bill of Lading when signing for the equipment. Remove the heater from the carton. If it is damaged, report the damage to the carrier immediately. Save the carton.

These items are shipped inside a box in the carton with the heater:

1. "Pagoda" top
2. In/Out flanges (2)
3. 2" CPVC female tailpiece, ring nut and o-ring
4. 2" flange gaskets (2)
5. Flange bolts (4)
6. Pressure relief valve
7. 2" CPVC adapter
8. Plastic pipe finish flange for gas line.
9. Bonding lug with mounting screw.
10. 2" CPVC manifold adapter
11. Prewired 1" flow switch with outdoor cover
12. Temperature & pressure gauge.

Be sure that you receive the number of packages indicated on the Bill of Lading.

When ordering parts, you must specify the model and serial numbers of the heater. See below for location of serial number. When ordering under warranty conditions, you must also specify date of installation.

The Model & Serial No.
can also be found inside
the bezel above the display

Alternate
Rating Plate
location

Model & Serial No.
located on
Rating Plate

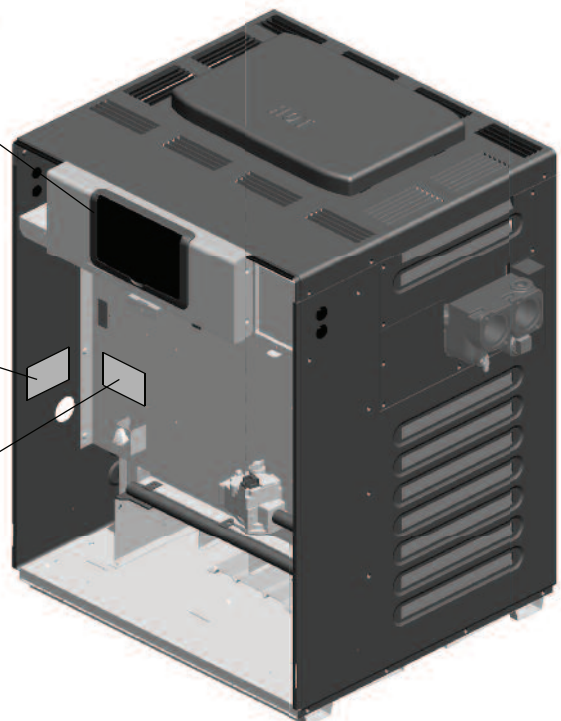

SECTION 2 - GENERAL SPECIFICATIONS

These heaters are design-certified and tested under the latest requirements of the ANSI Z21.56 / CSA 4.7 Standard for Gas-Fired Pool Heaters. All heaters can be used either indoor or outdoors. The appropriate top designated for each type of use is required. If necessary, the top can be changed at a later date to change from outdoor to indoor or vice versa.

Ambient Temperature Rating of Heater Components

Electronic Ignition Heater* -32°F to + 175°F

*Requires 120 or 240VAC Power Supply

Atmospheric heaters:

Rated inputs are suitable for up to 2,000 feet elevation. For elevations above 2000 feet, reduce input 4% for each 1,000 feet above sea level, as high elevation reduces combustion performance.

SECTION 3 - INSTALLATION INSTRUCTIONS

CALIFORNIA PROPOSITION 65 WARNING: This product contains chemicals known to the State of California to cause cancer, birth defects or other reproductive harm.

WARNING: This unit contains refractory ceramic fiber (RCF) insulation in the combustion chamber. RCF, as manufactured, does not contain respirable crystalline silica. However, following sustained exposure to very high temperatures (>2192F), the RCF can transform into crystalline silica (cristabolite). The International Agency for Research on Cancer (IARC) has classified the inhalation of crystalline silica (cristabolite) as carcinogenic to humans.

When removing the burners or heat exchangers, take precautions to avoid creating airborne dust and avoid inhaling airborne fibers. When cleaning spills, use wet sweeping or High Efficiency Particulate Air (HEPA) filtered vacuum to minimize airborne dust. Use feasible engineering controls such as local exhaust ventilation or dust collecting systems to minimize airborne dust. Wear appropriate personal protective equipment including gloves, safety glasses with side shields, and appropriate NIOSH certified respiratory protection, to avoid inhalation of airborne dust and airborne fiber particles.

IMPORTANT NOTICE

These instructions are intended only for the use by qualified personnel, specifically trained and experienced in the installation of this type of heating equipment and related system components. Installation and service personnel may be required by some states to be licensed. If your state is such, be sure your contractor bears the appropriate license. Persons not qualified shall not attempt to fix this equipment nor attempt repairs according to these instructions.

WARNING: *Improper installation, adjustment, alteration, service or maintenance may damage the equipment, create a hazard resulting in asphyxiation, explosion or fire, and will void the warranty.*

CODE REQUIREMENTS

NOTE: *The heater should not be located in an area where possible water leakage will result in damage to the area adjacent to the heater or to the structure. When such locations cannot be avoided, it is recommended that a suitable drain pan, with adequate drainage, be installed under the heater. The pan must not restrict combustion air flow.*

Installation must be in accordance with local codes, or, in the absence of local codes, with the latest edition of the National Fuel Gas Code, ANSI Z223.1/NFPA54 and National Electrical Code, ANSI/NFPA 70, and for Canada, the latest edition of CAN/CSA-B149 Installation Codes, and Canadian Electrical Code, CSA C22.1 Part 1 and Part 2.

CLEARANCES

ALL HEATERS

For clearances from combustible surfaces, see the chart below.

CLEARANCE FROM COMBUSTIBLE CONSTRUCTION	
INDOOR INSTALLATIONS:	
Top* - 30" (Drafthood)	Back - 6"
Front - Alcove (Open)	Right Side - 12" (Water Side)
Vent - 6"	Left Side - 6"
Floor** - 0"	(Opposite Water Side)
OUTDOOR INSTALLATION:	
Top* - Unobstructed (<i>Outdoor Stack</i>)	
Top*** - 36" (<i>Stackless Top</i>)	
Floor - 0"	Right Side - 12" (Water Side)
Back - 6"	Left Side - 6"
	(Opposite Water Side)

*Clearance from top of vent terminal.

**Do not install on carpeting.

***Clearance from top of heater.

When installed according to the listed minimum clearances from combustible construction, the pool heater can still be serviced without removing permanent construction around the heater.

However for ease of servicing, we recommend a clearance of at least 24" in the front, and at least 18" on the water connection side. This will enable the heater to be serviced in its installed location, that is, without movement or removal of the heater.

Clearances less than these (6" minimum), may require removal of the heater to service either the heat exchanger or the burner tray. In either case, the heater must be installed in a manner that will enable the heater to be serviced without removing any structure around the heater.

FLOORING: This heater can be installed on combustible flooring.

OUTDOOR HEATER INSTALLATION

These heaters are design-certified for outdoor installation, when equipped with the approved tops designated for outdoor use.

WARNING: The heater shall not be located in an area where water sprinklers, or other devices, may cause water to spray through the cabinet louvers and into the heater. This could cause internal rusting or damage electrical components, and void the warranty.

WARNING: Do not install within 3 feet of a heat pump or an outdoor condensing unit. Strong air intake from this type of equipment can disturb the combustion process and cause damage or personal injury.

HEATER WITH OUTDOOR STACKLESS TOP

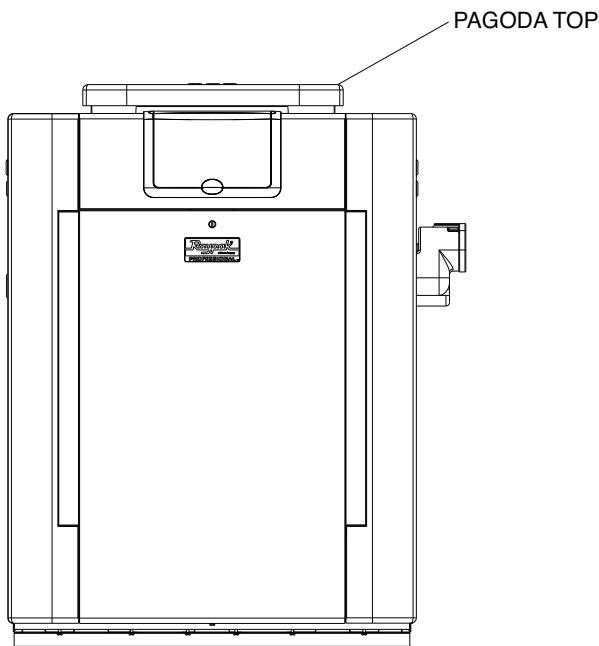

Pagoda Top Installation

1. Insert tabs into keyhole (4 places).

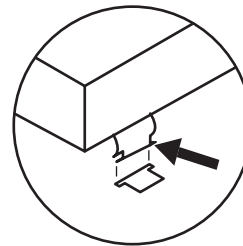

Pagoda Top
(Shipped inside
box in heater
carton)

2. Snap tabs into keyholes so as not to pull out.

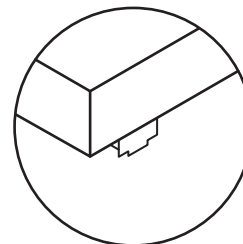

Heaters must not be installed under an overhang of less than three 3 ft from the top of the heater. Three sides must be open in the area under the overhang. Roof water drainage must be diverted away from the heaters installed under overhangs with the use of gutters.

For U.S. installations, the point from where the flue products exit the heater must be a minimum of 4 ft below, 4 ft horizontally from, or 1 ft above any door, window or gravity inlet into any building. The top surface of the heater shall be at least 3 ft above any forced air inlet, or intake ducts located within 10 ft horizontally.

For installations in Canada, pool heaters shall not be installed with the top of the vent assembly within 10 ft below, or to either side, of any opening into the building. Refer to the latest revisions of CAN/CSA-B149.

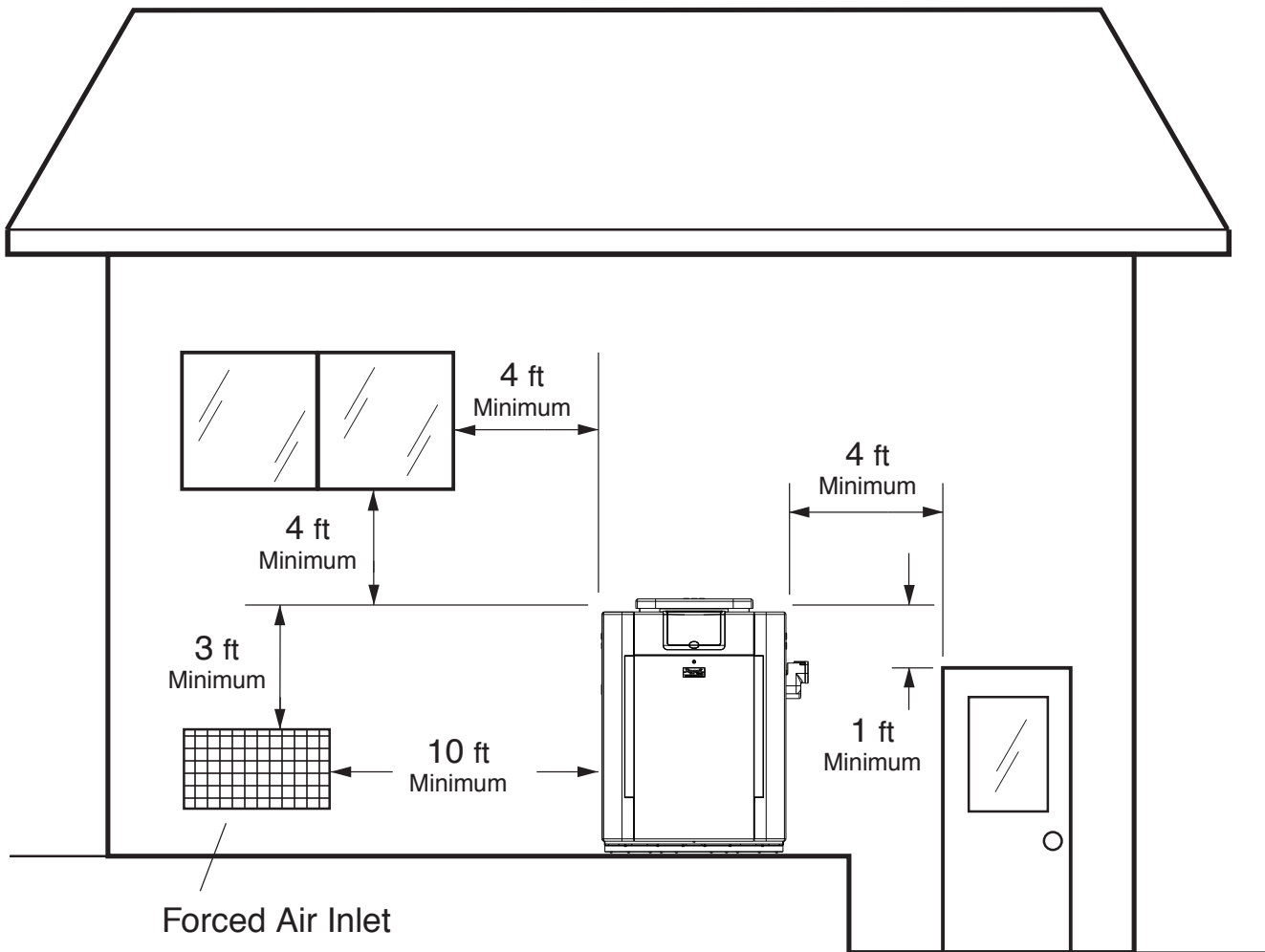

For installations in Florida and Texas, that must comply with the Florida or Texas Building Code, follow the directions on page 13 for the installation of hurricane tie-down brackets for all models.

FLORIDA AND TEXAS BUILDING CODES
WIND SPEED = 150 MPH, 3 SECOND GUST
EXPOSURE = C

268/408 Atmospheric

MODEL #	B
268	23"
408	29"

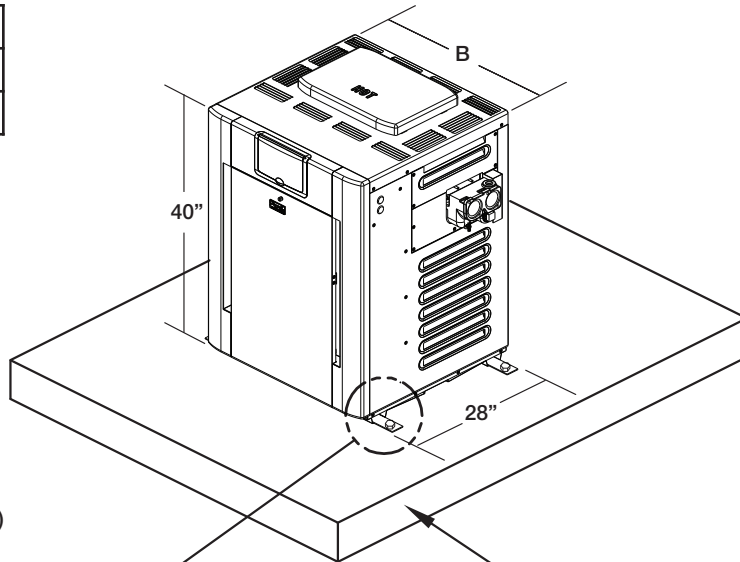

2" x 6" x 1/8" Pallet
Anchor Bracket (4 Total) (Kit# 011636)

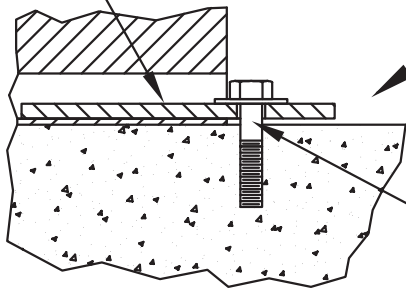

1/4" x 1-3/4" S.S. Tapcon Bolt & Washer (Field Supplied)
 NOTE: Use hole closest to unit with
 washer overlapping edge of unit.

3" Min. Conc.
Pad by others

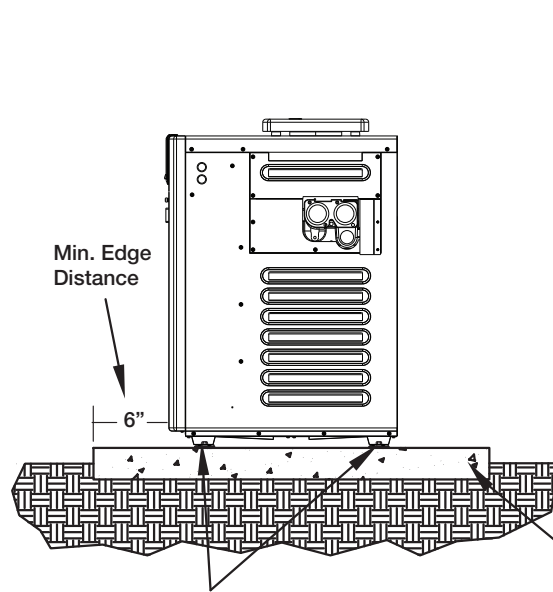

(1)-1/4" x 1-3/4" S.S. Tapcon Bolt & Washer (Field Supplied)
 Ea. Pallet Anchor Bracket
 Use hole closest to unit (4 total)

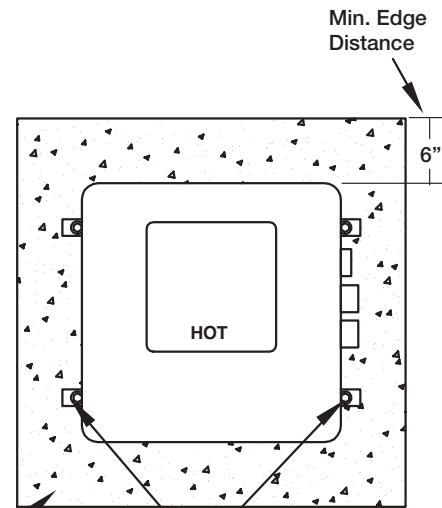

(1)-1/4" x 1-3/4" S.S. Tapcon Bolt & Washer (Field Supplied)
 Ea. Pallet Anchor Bracket
 Use hole closest to unit (4 total)

3" Min. Conc.
Pad by others

INDOOR HEATER INSTALLATION

The heater is also design-certified for indoor installation when equipped with the approved draffhood.

For Canada, indoor installation is restricted to an enclosure that is not occupied and does not directly communicate with an occupied area. Refer to the latest edition of CAN/CSA-B149 for specific requirements. Locate heater as close as is practical to a chimney or gas vent. Heater must always be vented to the outside. See Vent Piping section (pg. 16-17) for details. Minimum allowable space is shown on the nameplate.

WARNING: Indoor heaters require a draffhood that must be connected to a vent pipe and properly vented to the outside. Failure to follow this procedure can cause fire or fatal carbon monoxide poisoning.

OUTDOOR STACK / INDOOR STACK

NOTE: The outdoor and indoor stacks are optional equipment and do not come standard with the heater.

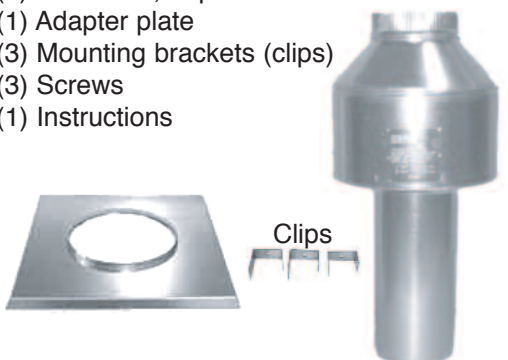
<p><u>OUTDOOR STACK KIT INCLUDES:</u></p> <ul style="list-style-type: none"> (1) Draffhood, painted (1) Adapter plate (3) Mounting brackets (clips) (1) Top panel cover (2) 1-foot sections of metal tape (3) Screws (1) Instructions 	<p><u>INDOOR STACK KIT INCLUDES:</u></p> <ul style="list-style-type: none"> (1) Draffhood, unpainted (1) Adapter plate (3) Mounting brackets (clips) (3) Screws (1) Instructions 
--	--

NOTE: The outdoor draffhood kit does not require any additional vent pipe for proper operation. This draffhood functions as the vent termination.

	OUTDOOR STACK	INDOOR STACK
Model	Part No.	Part No.
268	009835	009839
408	009837	009841

****REFER TO INSTALLATION INSTRUCTIONS INSIDE BOX FOR INSTRUCTIONS ON HOW TO INSTALL OUTDOOR/INDOOR STACK.**

SPECIFICATIONS AND DIMENSIONS

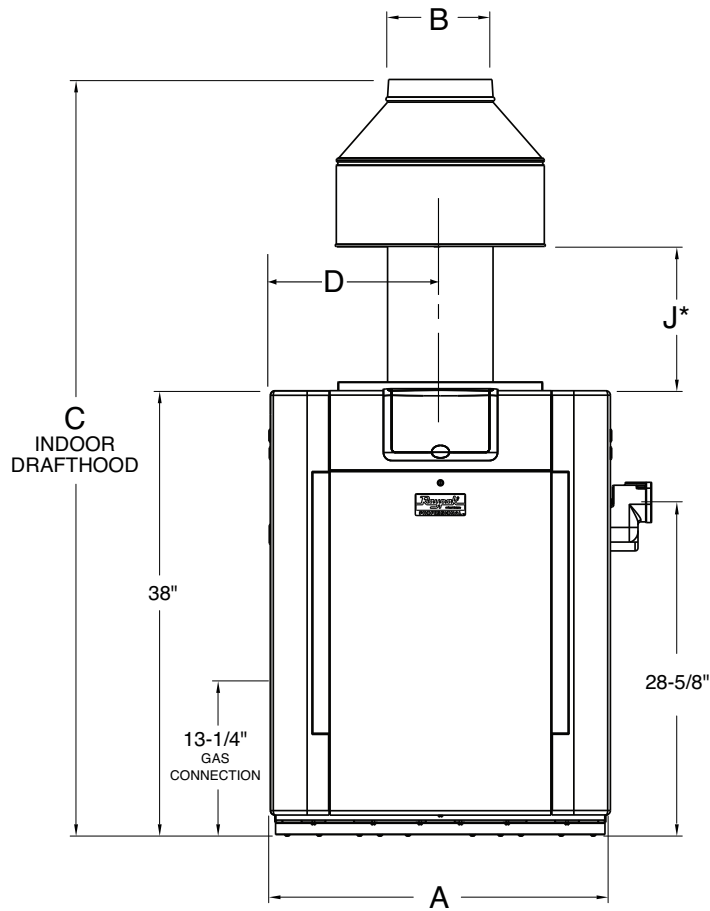

Amp Draw	
120 Volt	240 Volt
4	2

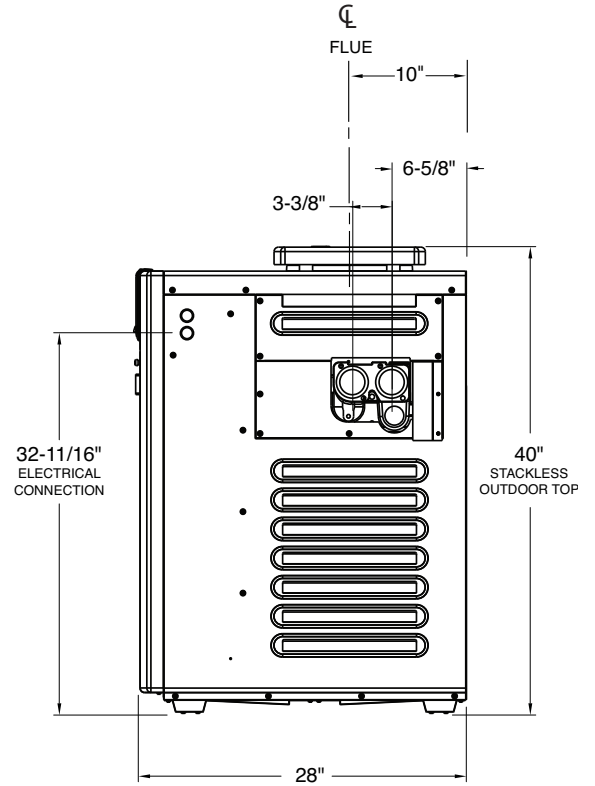

Heater Model	BTUH Input (000)	(A) Cabinet Width	(B) Flue Dia.	(C) Indoor Draft Hood	(D)	(J) Min.	Gas Conn.	Water Conn.	Shipping Weights (lbs)		
									Standard Heater w/Stackless Top	ASME Heater w/Stackless Top	Indoor Draft-hood
R268	266.0	23"	7"	62"	11.5"	11"	3/4"	2"	210	229	16
R408	399.0	29"	9"	64-9/16"	14.5"	12-1/8"	3/4"	2"	249	268	21

Designation for a heater using propane gas is "EP"; a heater using natural gas is "EN".

Prefix "B" is for brass (ASME) headers.

Suffix "X" is for cupro-nickel tubing.

EXAMPLE: **B-R408-EN-X** = Brass headers, 408 model size, AFT, natural gas, cupro-nickel.

Reduce input 4% for each 1000 ft above sea level when installed above 2000 ft elevation.

For Canada, no de-rating is required for elevations up to 4500 ft

*Note: For outdoor stack, use J dimension in the table above for appropriate size PLUS six (6) inches.

**COMBUSTION AND VENTILATION AIR
(Indoor Units Only)**

The heater must have both combustion and ventilation air. Minimum requirements for net free air supply openings are one opening that is 12 inches from the ceiling for ventilation, and one opening that is 12 inches from the floor for combustion air as outlined in the latest edition of the National Fuel Gas Code, ANSI Z223.1(Canada-CAN/CSA-B149) and any local codes that may have jurisdiction.

A. All Air From Inside The Building:

Each opening shall have a minimum net free area as noted:

Model	Square Inches	Model	Square Inches
268	266	408	399

B. All Air From Outdoors:

When air is supplied directly from outside the building, each opening shall have a minimum net free area as noted:

Model	Unrestricted Opening (sq. in.)	Typical Screened <i>or</i> Louvered Opening (sq. in.)	Typical Screened <i>and</i> Louvered Opening (sq. in.)
268	67	101	134
408	100	150	200

CAUTION: Combustion air must not be contaminated by corrosive chemical fumes which can damage the heater and void the warranty.

VENT PIPING

WARNING: Indoor heaters require a draft hood that must be connected to a vent pipe and properly vented to the outside. Failure to follow this procedure can cause fire or fatal carbon monoxide poisoning.

Vent piping the same size as the draft hood outlet is recommended, however, when the total vent height is at least 10 ft (draft hood relief opening to vent terminal), the vent pipe size may be reduced as specified in Chapter 10 of the National Fuel Gas Code, **ANSI Z223.1 (Canada - CAN/CSA-B149)**. As much as possible, avoid long horizontal runs of vent pipe and too many elbows. If installation requires horizontal runs, the vent pipe must have a minimum of 1/4 in. per ft rise and should be supported at not more than five foot intervals. Plumbers tape, criss-crossed, will serve to space both horizontal and vertical piping. Gas vents supported only by the flashing and extending above the roof more than five feet should be securely guyed or braced to withstand snow and wind loads. We recommend use of insulated vent pipe spacers through the roofs and walls. Another option for installation that requires horizontal runs is using the D-2 power vent kit option.

Power Vent Kit		
Model	120 VAC Part No.	240 VAC Part No.
268	010744	009832
408	010745	009833

The D-2 Power Vent operates with a positive vent static pressure and with a vent gas temperature that prevents excessive condensate production in the vent, and as such, is a CATEGORY III appliance.

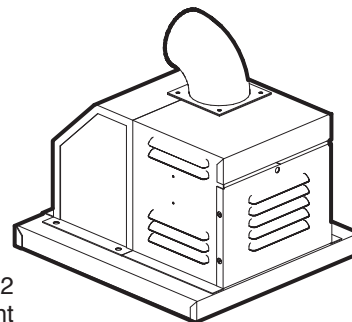

Optional Raypak D-2
Power Vent

For more information consult the D-2 Power Vent manual, (Catalog No. 6000.57.1).

The unit, when installed as directed, is capable of operating in applications such as through-the-wall venting and reduced horizontal and vertical vent pipe sizes in new and current installations. The unit is factory-wired for 240 VAC, with capability of rewiring for 120 VAC.

For protection against rain or blockage by snow, the vent pipe must terminate with a vent cap which complies with the local codes or, in the absence of such codes, to the latest edition of the National Fuel Gas Code, **ANSI Z223.1 (Canada - CAN/CSA-B149)**.

The discharge opening must be a minimum of 2 ft vertically from the roof surface and at least 2 ft higher than any part of the building within 10 ft. Vent stack shall be at least 5 ft in vertical height above the draft hood outlet. The vent cap location shall have a minimum clearance of 4 ft horizontally from, and in no case below, unless a 4 ft horizontal distance is maintained, from electric meters, gas meters, regulators and relief equipment.

The weight of the vent stack or chimney must not rest on heater draft hood. Support must be provided in compliance with applicable codes. The heater top and draft hood must be readily removable for maintenance and inspection. Vent pipe should be adequately supported to maintain proper clearances from combustible construction.

Type "B" double-wall or equivalent vent pipe is recommended. However single-wall metal vent pipe may be used as specified in the latest edition of the National Flue Gas Code **ANSI Z223.1 (Canada - CAN/CSA-B149)**.

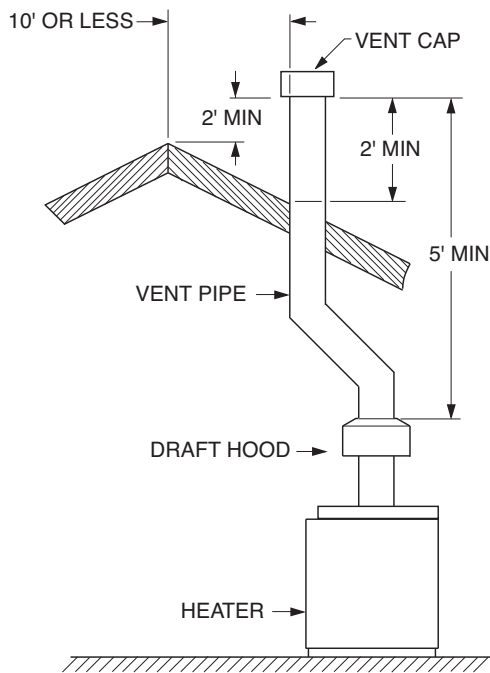

NOTE: With venting application of two or more heaters, contact the factory.

GAS SUPPLY CONNECTIONS

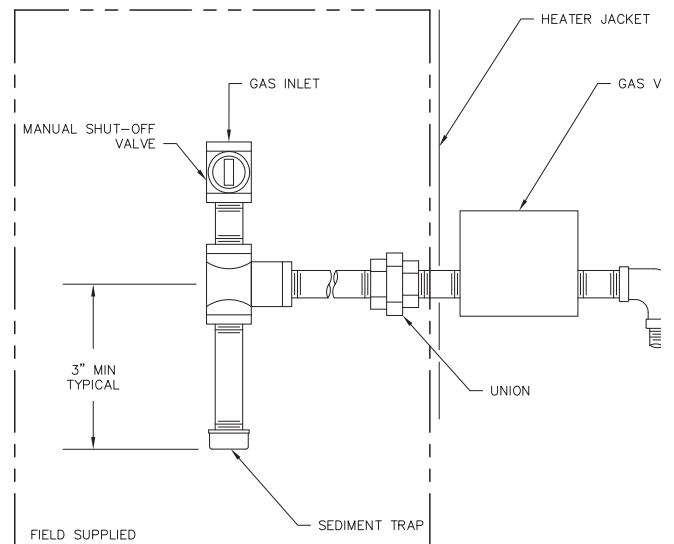

Gas piping must have a sediment trap ahead of the heater gas controls, and a manual shut-off valve located outside the heater jacket. All gas piping should be tested after installation in accordance with local codes.



CAUTION: The heater and its manual shut-off valve must be disconnected from the gas supply during any pressure testing of that system at test pressures in excess of 1/2 psi (3.45 kPa). Dissipate test pressure in the gas supply line before reconnecting the heater and its manual shut off valve to gas supply line. **FAILURE TO FOLLOW THIS PROCEDURE MAY DAMAGE THE GAS VALVE. OVER PRESSURIZED GAS VALVES ARE NOT COVERED BY WARRANTY.** The heater and its gas connections shall be leak tested before placing the appliance in operation. Use soapy water for leak test. **DO NOT** use open flame.

NOTE: Do not use Teflon tape on gas line pipe thread. A pipe compound rated for use with natural and propane gases is recommended. Apply sparingly only on male pipe ends, leaving the two end threads bare.

SUPPLY PRESSURES

A minimum of 6 in. WC and a maximum of 14 in. WC upstream pressure under load and no-load conditions must be provided for natural gas. A minimum of 12 in. WC and a maximum of 14 in. WC are required for propane gas under load and no-load conditions.

GAS PRESSURE REGULATOR

The gas pressure regulator is preset at 4.0 in. WC throughout for natural gas, and 10.5 in. WC for propane gas. The pressure at the gas valve, taken with a manometer, should be about 4.0 in. WC natural gas and 10.5 in. WC propane gas. If an adjustment is needed, remove seal and turn adjustment screw clockwise  to increase pressure or counter-clockwise  to decrease pressure.

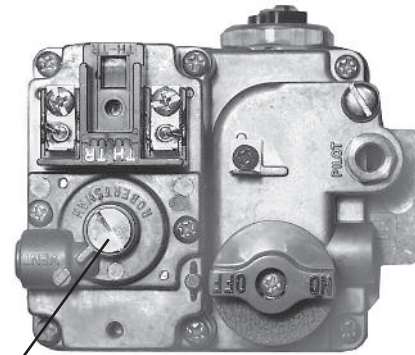
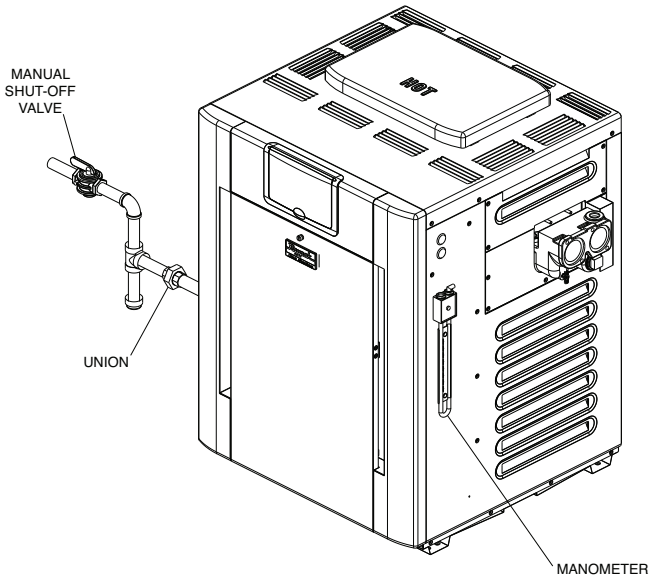

Gas Pressure Adjustment

**Robertshaw 7000 BDER
(Heater Model 268)**

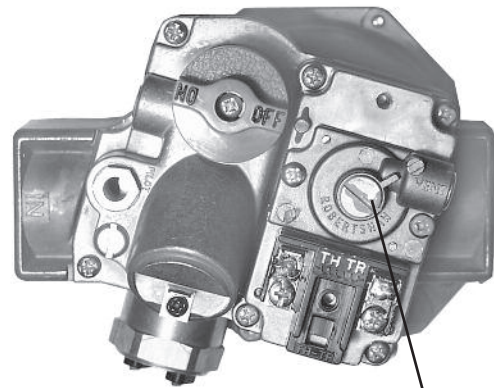

Gas Pressure Adjustment

**Robertshaw 7000 DERHC
(Heater Model 408)**

GAS PRESSURE ADJUSTMENT LOCATIONS

Gas Pressure Adjustment

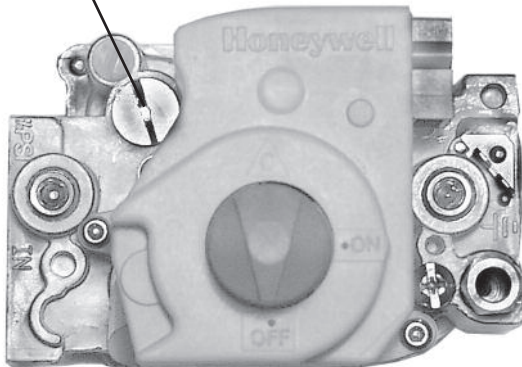

**Honeywell VR8304
(Heater Models 268 and 408)**

PIPE SIZING FOR GAS CONNECTIONS

Maximum Equivalent Pipe Length (ft)									
Natural Gas 1000 BTU/FT ³ 0.60 Specific Gravity @ 0.5 in. WC Pressure Drop									
Propane Gas 2500 BTU/FT ³ 1.53 Specific Gravity @ 0.5 in. WC Pressure Drop									
	Input	3/4"		1"		1-1/4"		1-1/2"	
Model	(KBTU)	N	P	N	P	N	P	N	P
268	266.0	15	35	50	125	210	480	445	
408	399.0	*	15	20	55	95	225	215	480

*A 3/4" gas line can be used for up to 5 ft maximum length from the gas valve in addition to the sediment trap.

FLOW RATES

MODEL	PIPE SIZE	MIN. GPM	MAX. GPM*
268	1-1/4"-1-1/2" - 2"	25	125
408	1-1/4"-1-1/2" - 2"	40	125

*When flow rates exceed maximum GPM an external auxiliary bypass valve is required. See external bypass valve section for details.

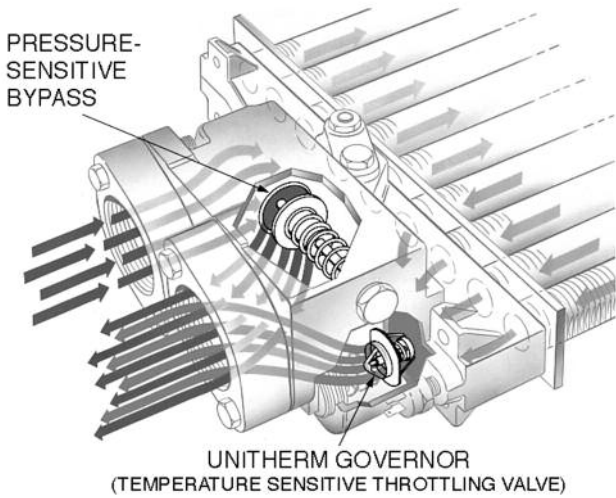

HEAT EXCHANGER PRESSURE DROP

FLOW GPM	PRESSURE DROP (FT OF HEAD)	
	268	408
30	8.0	
40	9.0	9.0
50	9.8	9.8
60	10.5	10.5
70	11.0	11.0
80	11.5	11.5
90	14.0	14.0
100	17.0	17.0

WATER CONNECTION INSTALLATION

Gather the loose items that were shipped with the heater. They will be as shown below:

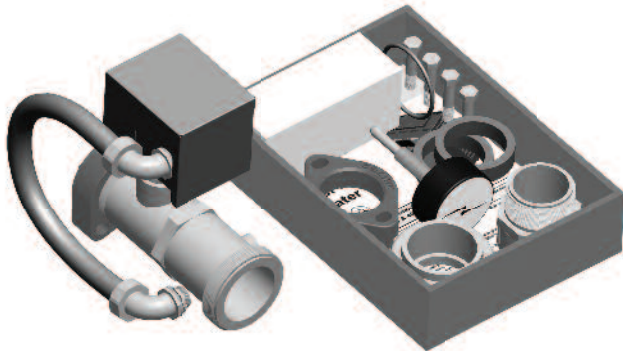

The components should be assembled onto the inlet/outlet header of the unit as shown below.

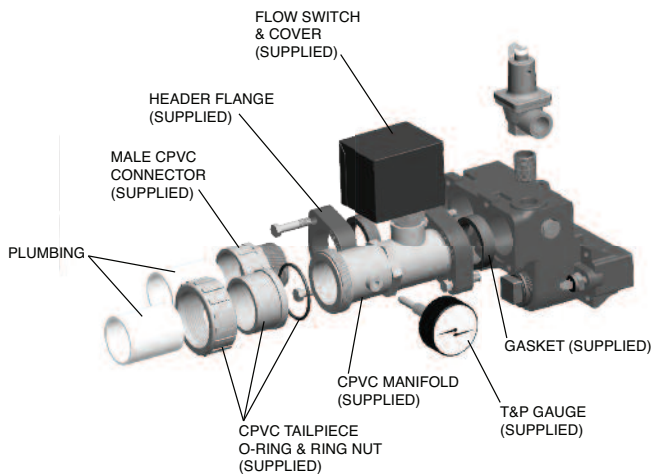

Once all components are in place and installed properly, the water connections will appear as shown below:

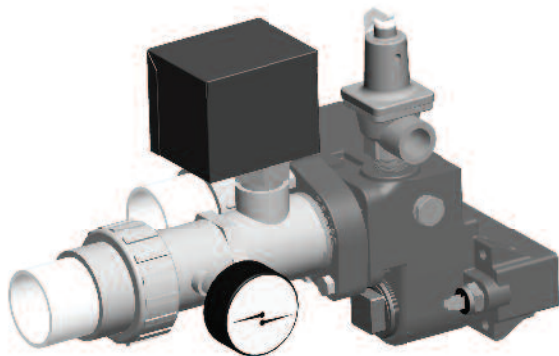

The heater must be located so that any water leaks will not damage the structure of adjacent area. High temperature 2" plastic pipe (CPVC) may be threaded directly into the header flanges. This is not the same as the Schedule 80 PVC pipe which is also gray. PVC may be used immediately after the supplied CPVC adapters.

DO NOT use petroleum-based assembly fluids (such as petroleum jelly or lubricating oil). If assembly lube is required, use a silicon base such as AquaLube etc.

UNITHERM GOVERNOR OPERATION

CAUTION:

The patented Unitherm Governor is a thermostatic mixing valve specifically designed to maintain constant heater internal temperature between 105° and 115°F despite continually changing flow rates from the filter and changing pool temperatures. This narrow range is needed to prevent damaging condensation on the burners which will occur if the heater runs for any length of time below 100°F. It is also needed to inhibit scale formation in the tubes by maintaining temperatures well below accelerated scaling temperatures.

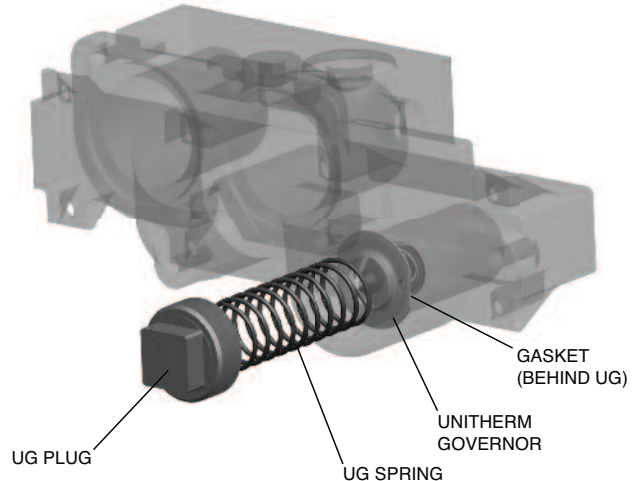

INTERNAL AUTOMATIC BYPASS VALVE

In addition to the Unitherm Governor, a built-in automatic bypass valve is provided in the in/out header. While the Unitherm Governor responds to the changes in water temperature in the heater, the internal bypass valve automatically responds to changes in water pressure in the piping system. Proper amount of water flow is maintained through the heater under varying pressures dictated by the conditions of the pump and filter.

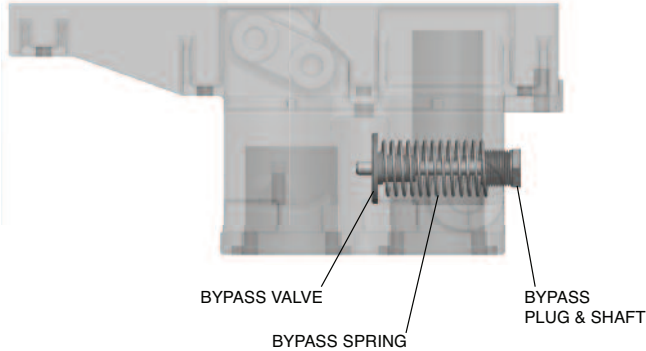

EXTERNAL AUXILIARY BYPASS VALVE

(Where Required)

An auxiliary bypass valve should be used when flow rates exceed 125 GPM. Usually a high-performance pump size larger than two horsepower will exceed this flow rate. This valve is required to complement the function of the automatic bypass valve, particularly when starting the heater in winter or early spring when the spa or pool temperature is below 50°F. It also serves to eliminate needless pressure drop through the heater and accompanying reduction in the flow rate to the spa jets, etc.

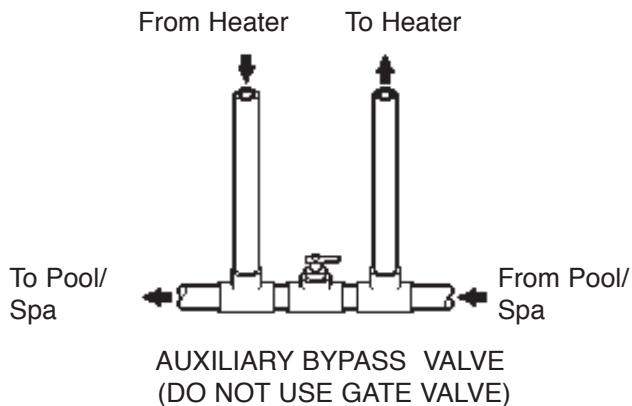

AUXILIARY BYPASS VALVE ADJUSTMENT

To set bypass: With clean filter, adjustment is made by feeling the inlet and outlet pipes at the heater. Outlet pipes should be slightly warmer than inlet and comfortable to the touch. If pipe is hot, close bypass; if cold, open bypass.

PRESSURE RELIEF VALVE INSTALLATION

To conform to local building codes, it may be necessary to install a pressure relief valve. A 3/4" pressure relief valve, having a capacity equal to the BTUH output of the model to be installed, is recommended for this heater. The maximum acceptable pressure relief valve setting is 125 psi.

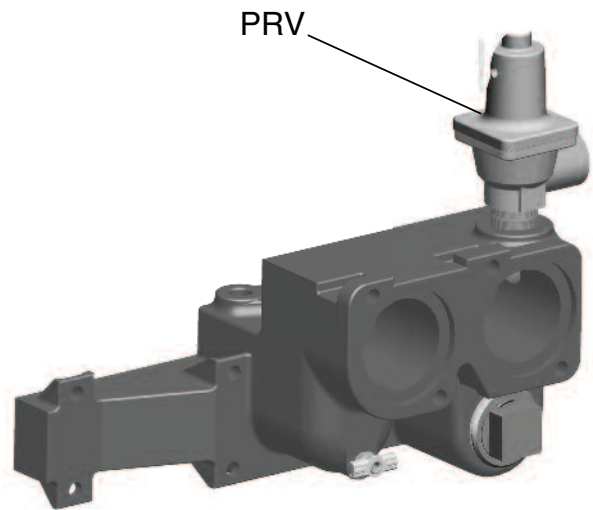

NOTE: To avoid water damage or scalding due to valve operation, drain pipe must be connected to valve outlet and run to a safe place of discharge. Drain pipe must be the same size as the valve discharge connection throughout its entire length and must pitch downward from the valve. No shut-off valve shall be installed between the relief valve and the drain line. Valve lever should be tripped at least once a year to ensure that waterways are clear.

PLUMBING—WATER CONNECTIONS

Single Pool Heater Installation

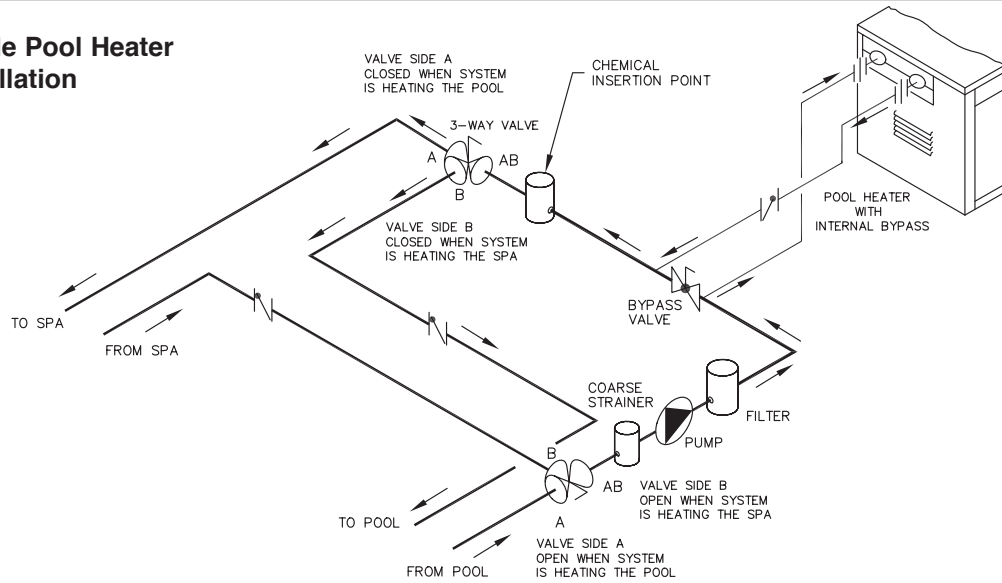

THIS DIAGRAM IS RAYPAK'S RECOMMENDATION AND IS NOT INTENDED TO REPLACE AN ENGINEERED PIPING SYSTEM BY A PROFESSIONAL ENGINEER.

KEY	
	ISOLATION VALVE
	BALL VALVE
	PRESSURE RELIEF VALVE
	PUMP
	UNION
	CHECK VALVE

Multiple Pool Heater Installation

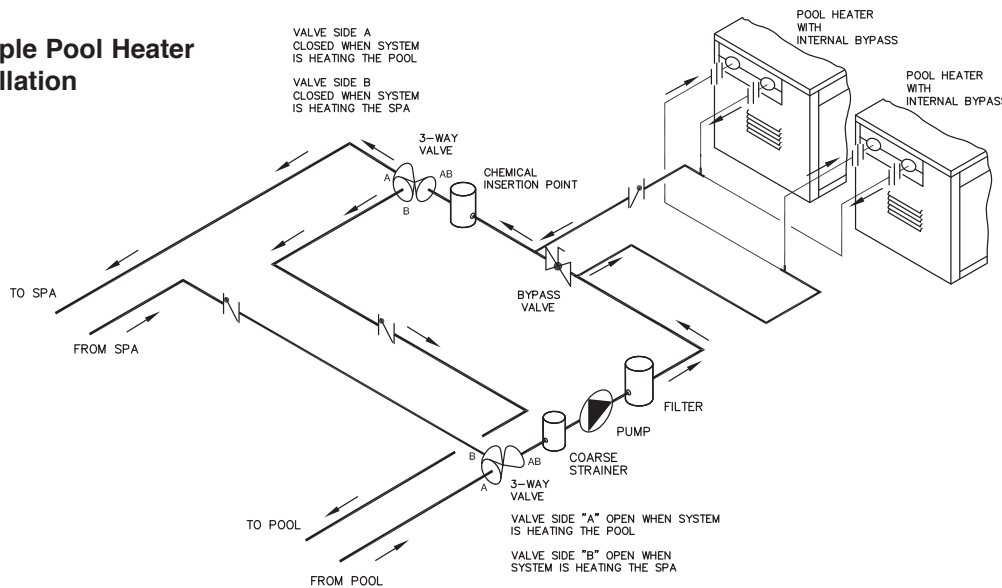

THIS DIAGRAM IS RAYPAK'S RECOMMENDATION AND IS NOT INTENDED TO REPLACE AN ENGINEERED PIPING SYSTEM BY A PROFESSIONAL ENGINEER.

The heater requires water flow and positive pressure to fire and operate properly. It must therefore be installed downstream of the discharge side of the filter pump. A typical installation is plumbed as follows:

1. The inlet side of the filter is plumbed directly to the discharge side of the filter pump;
2. The outlet side of the filter is then plumbed to the inlet of the heater; and
3. The outlet of the heater is plumbed to the return line to the pool or spa. The pump, filter and heater are thus plumbed in series (Salt generators and chemical feeders must be down stream of the pool heater).

Plumbing from the heater back to the pool or spa must not have any valves or restriction that could prevent flow when the pump is operating.

CAUTION: An additional source of heated water, e.g. a solar system, must be connected to the main line ahead of the heater inlet pipe in order for it to act as the primary heat source. If the primary system provides adequate heat to maintain set-point, the heater will not fire. Be advised that the control panel will then display sensed water temperatures downstream of the primary heating system, rather than the temperature of the water exiting the pool.

Heater must be located so that any water leaks will not damage the structure of adjacent area.

ELECTRICAL WIRING

NOTE: If it is necessary to replace any of the original wiring, use 105°C wire or its equivalent, and/or 150°C wire or its equivalent, like the original wiring.

WARNING:

Heaters are factory-wired for **240 VAC** power supply. **DO NOT attempt to operate at 208 VAC.**

The standard field-wiring connection is on the right side of the heater.

To wire the heater from the left side, follow these steps :

1. Remove the two (2) screws that hold the front door to the heater. Remove and set aside door for better access to wiring.
2. Remove the four (4) screws that hold down the junction box to the sway brace.
3. Remove the transformer cover located on the far right by removing one (1) screw.
4. Remove the two (2) screws that hold down the transformer.
5. Remove the one (1) screw that holds down the ground wires.
6. Disconnect P6 connector from PC board.
7. Remove transformer from its current location and relocate it on the far left side of the heater.
8. Re-route all high-voltage wires and ground wires through the left jacket side of heater.
9. Re-install P6 connector, ground wires (SPG), transformer, junction box, front door, and plug right side with the left side's grommet plug.

NOTE: 7/8" dia. holes not utilized on jacket and control box can be used for fireman switch, auxiliary control interface or power vent (D-2) wiring.

CAUTION: Heater must be electrically grounded and bonded. Bonding lug is provided loose with the heater. Install bonding lug on lower right or left side of jacket as necessary for bonding the heater. Mounting hole is provided on the jacket.

NOTE: Failure to ground the heater electrically could affect the heater's electronics.

The Electronic Intermittent Ignition Device automatically lights the pilot and main burners upon a call for heat. The heater is supplied with a dual-voltage transformer for 120 VAC or 240 VAC input power hookup.

NOTE: See page 32 for further instructions if using a time clock/fireman's switch.

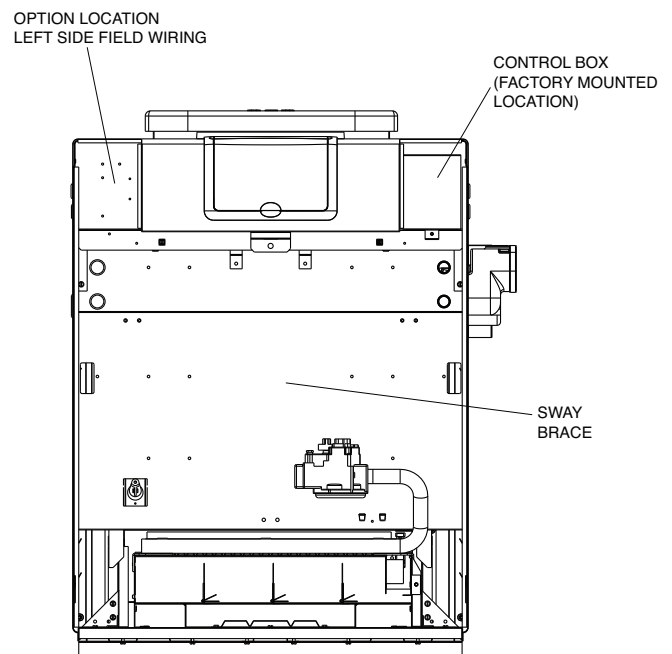

Wiring locations

TRANSFORMER WIRING

120 VAC WIRING

For 120 VAC input power to the unit, connect the black wire to the “L1” or hot leg of the power supply. Connect the white wire to the “Ret” or neutral leg of the power supply. Attach the wire nut to the red wire. **There should be no connection to the red wire for 120 VAC operation.**

120V ATMOSPHERIC HEATER

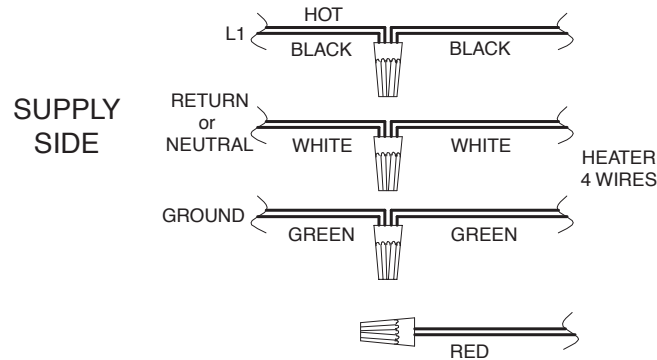

240 VAC WIRING

For 240 VAC input power to the unit, connect the black wire to the “L1” or hot leg of the power supply. Connect the red wire to the “L2” or second hot leg of the power supply. Attach the wire nut to the white wire. **There should be no connection to the white wire for 240 VAC operation.**

WARNING: DO NOT attempt to operate the heater at 208 VAC.

240V ATMOSPHERIC HEATER

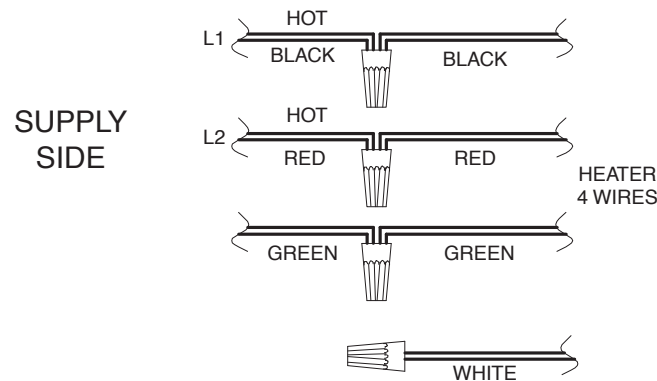

Heater must be electrically grounded and bonded in accordance with local codes, or, in the absence of local codes, with the latest edition of the National Electrical Code, ANSI/NFPA 70. (Canada - Canadian Electrical Code, CSA C22.1, Part 1 and Part 2.)

NOTE: If the transformer’s primary side is wired for 120 VAC and 240 VAC is applied, damage to the transformer and PC board may result. Such damages are not covered under manufacturer’s limited warranty.

NOTE: Input power to the heater (120 or 240 VAC) can be supplied from the load (pump) side of time clock or directly from the GFCI power source. **It is preferred that full-time power be supplied to the heater from the GFCI power source, and that the heater be controlled by the fireman’s switch connection or using a two or three-wire remote. See pages 30-32.** If using a switched GFCI power source, the heater could display false service indicators on the display panel if the pump is turned off.

WIRING DIAGRAM

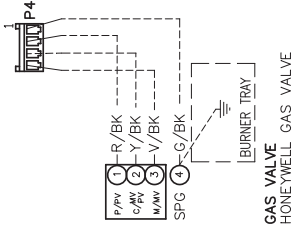
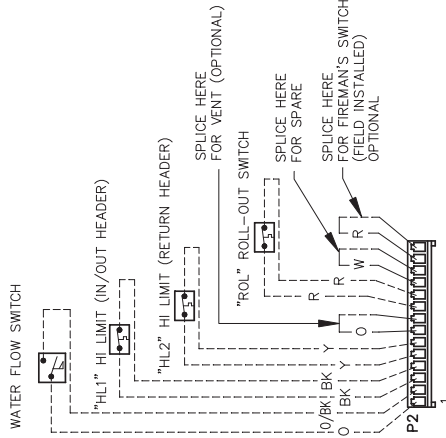
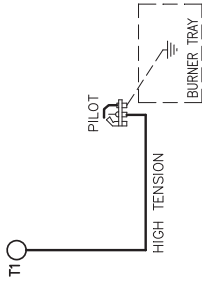
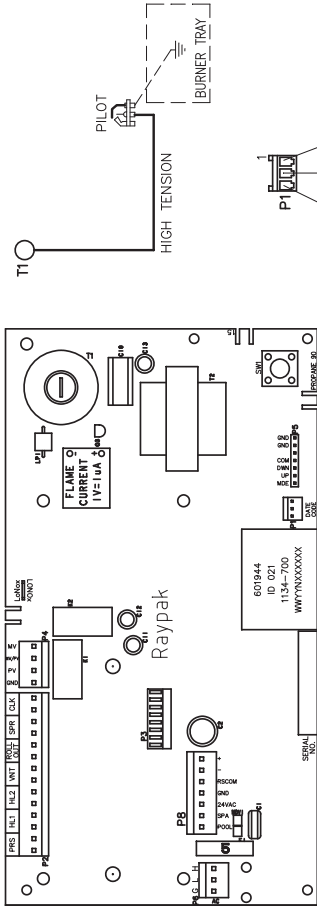

GAS VALVE
HONEYWELL GAS VALVE

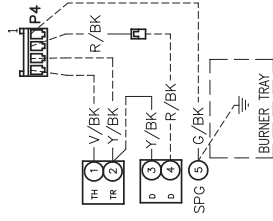

GAS VALVE
INVENSTYS GAS VALVE

KEY	
—	24V 105°C
- - -	24V 150°C
- - -	120V 105°C
- - -	120V 150°C
○	WIRE NUT
⊕	GROUND
⊕	GROUND
BK	BLACK
BR	BROWN
BL	BLUE
G	GREEN
O	ORANGE
R	RED
V	WHITE
W	WHITE
Y	YELLOW
⊖	MALE/FEMALE
⊖	TERMINAL CONN
152987 A	

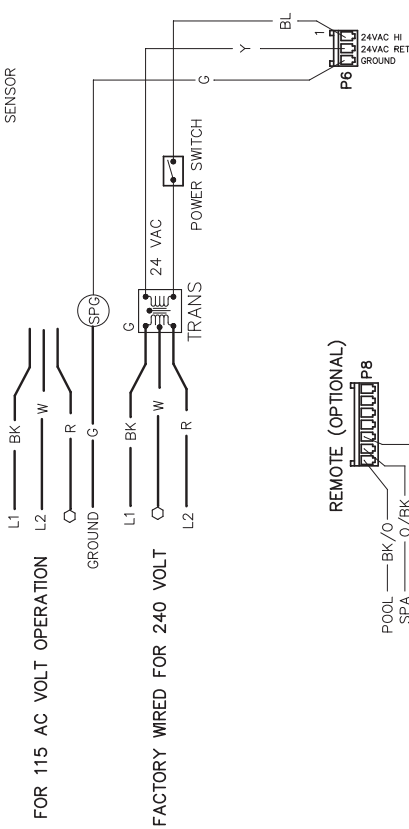

SECTION 4 - SERVICING INSTRUCTIONS

GENERAL LOCATION OF CONTROLS

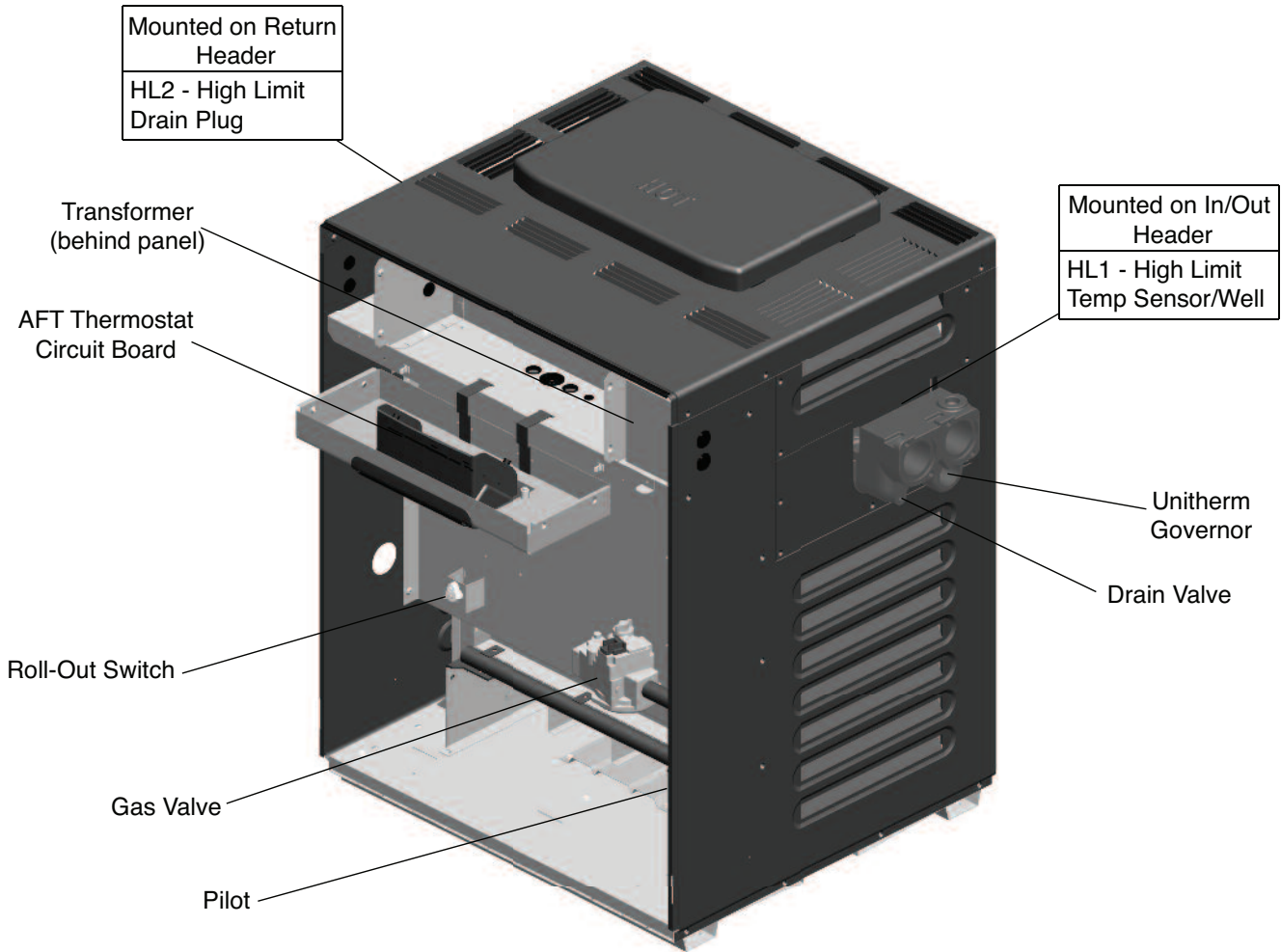

CONTROL PANEL REMOVAL

1. Remove screw from front door. Set aside door for serviceability.

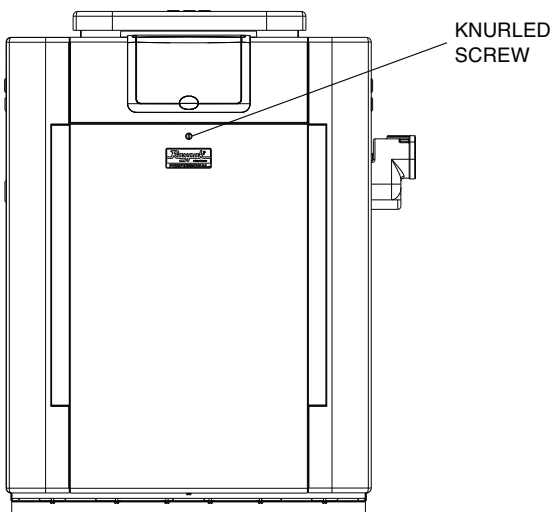

2. Remove (4) screws from sides of control panel.
3. Rotate control panel down until panel stops. Do not force.

NOTE: Caution must be used to not damage controls or wiring.

CONTROL ADJUSTMENTS

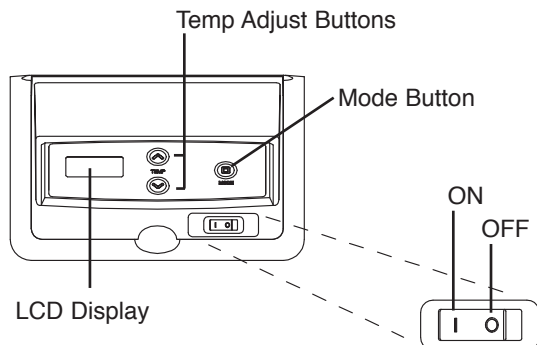

THERMOSTAT OPERATION - ADVANCED FLAME TECHNOLOGY (AFT) BOARD

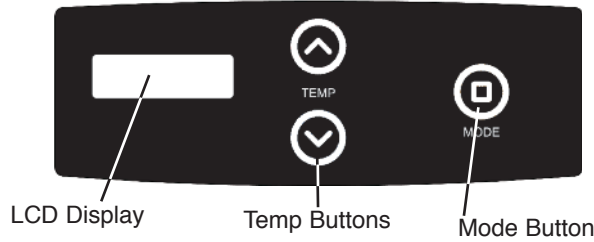

The pool heater touchpad, located on the upper front panel of the heater, allows the user to select either POOL or SPA operation, and to adjust the setpoint temperature. The LCD display window indicates the mode (OFF, SPA, POOL) and the actual water temperature. A manual power switch provided below the touchpad turns the control power ON or OFF.

Mode Button

The MODE button is used to select either POOL or SPA operation. It also allows the user to turn the heater off electronically, allowing the LCD display to remain energized and to continue showing the actual water temperature.

Temp Buttons

If the heater is in POOL or SPA mode, the desired water temperature (SETPOINT) will also be displayed and may be adjusted using the UP or DOWN buttons.

Operation

In the POOL or SPA modes, the actual water temperature is displayed along with the desired water temperature (SETPOINT). When the water temperature is above the setpoint, "Water Temp" will alternate with "No Demand." When the water temperature is below the setpoint and the heater is firing, "Water Temp" will alternate with "Heating."

To adjust the setpoint temperature, make sure the control is in the appropriate mode (POOL or SPA) and push the UP or DOWN buttons.

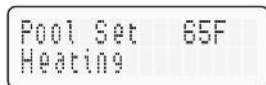

ALTERNATING DISPLAYS DURING HEATING

Service Menu and Fault History

To access the Service Menu and fault history, press the MODE and UP buttons simultaneously for 3 to 5 seconds. The heater will continue to operate normally while in the Service Menu. The first screen displayed is the Flame Strength indicator, which indicates

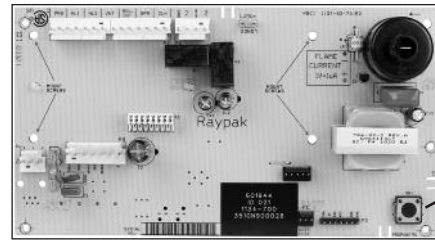

the pilot flame current using a bar graph and numerical display. A signal of less than 4 indicates a weak flame signal and may require service. Refer to Section 5 – Troubleshooting for possible causes and corrections.



FLAME STRENGTH INDICATOR

Press the DOWN button. The Supply Voltage screen indicates the voltage supplied to the control board. Normal readings range from 24 to 29 volts.

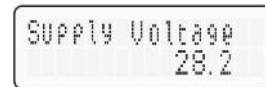

SUPPLY VOLTAGE INDICATOR

Press the DOWN button. The Run Time indicates the total hours of operation for the pool heater, as measured by the amount of time that the main gas valve has been powered. The Cycle count indicates the number of on/off cycles of the heater, as measured by the number of times the pilot valve has been powered.

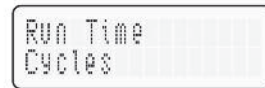

RUN TIME INDICATOR



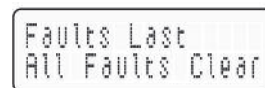

Press the DOWN button. The Fault History can display up to ten faults in memory. The order of the faults begins with "Fault Last," which is the most recent fault, and proceeds through ten most recent messages in chronological order. The second line of the display shows the fault message. If there are no faults in the history buffer, the second line reads "All Faults Clear."

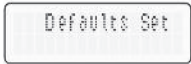

FAULT HISTORY

Program Button

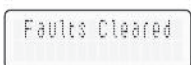
- 1) Remove the four screws holding the control cover, and swing the panel down so the back side of the board is visible (see page 26). Locate the Program Mode button (marked as SW1) as shown on page 27. Press and hold the button (5-7 seconds) until **Set Factory Defaults** appears on the display. Release the program button.
- 2) Press the **Mode** button sequentially until the desired program event is reached. There are 5 different events that can be programmed. They appear in the sequence listed below:

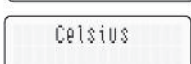
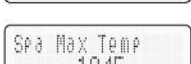
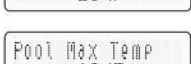
	Resets board to factory default settings.
	
	
	Resets faults in the History File.
	
	Change from Fahrenheit to Celsius.
	SPA setpoint maximum adjustment.
	POOL setpoint maximum adjustment.

Set Factory Defaults

Refer to step one above to access the program screen. **Set Factory Defaults** should appear on the screen. If it does not, press the **Mode** button until **Set Factory Defaults** appears on the digital display. Press and hold both UP and DOWN buttons for 5-7 seconds until **Defaults Set** appears. This operation resets the operating program to its factory default values. Both the POOL and SPA setpoints will revert to 65°F (18.5°C) and both POOL and SPA maximum temperature settings will be 104°F (40.0°C). The Control Lockout PIN will be cleared and the control will resume normal operation.

Clear Faults

Refer to step one above to access the program screen. Press the **Mode** button until **Clear Faults** appears on the digital display. Press and hold both UP and DOWN buttons for 5-7 seconds until **Faults Cleared** appears. This operation resets the Fault History file to "0" and clears all the stored faults.

Fahrenheit or Celsius

Refer to step one above to access the program screen. Press the **Mode** button until **Fahrenheit** or **Celsius** appears on the digital display. The digital display is capable of displaying Celsius as well as Fahrenheit temperatures. The UP or DOWN buttons will select **Fahrenheit** or **Celsius** on the temperature display. Choose the desired temperature scale.

Spa Max Temp – Spa Set Point Maximum Adjustment

Refer to step one above to access the program screen. Press the **Mode** button until **Spa Max Temp** appears on the digital display. Using the UP and DOWN buttons will change the Maximum Temperature Setting to your desired value. The control can be set for a maximum of 107°F.

Pool Max Temp – Pool Set Point Maximum Adjustment

Refer to step one above access into the program screen. Press the **Mode** button until **Pool Max Temp** appears on the digital display. Using the UP and DOWN buttons will change the Maximum Temperature Setting to your desired value. The control can be set for a maximum of 107°F.

Control Lockout

The heater is equipped with a Control Lockout feature to prevent unauthorized tampering or adjustment of the control settings. To lock out the controls, press the DOWN button and **Mode** button for 5 seconds. Choose a three digit PIN, using the UP and DOWN buttons to select the digits and the **Mode** button to lock in selections. Confirm your selection and record your PIN.

To unlock the controls, press any button to bring up the **Enter PIN** menu. Enter the PIN that was used to lock the control. Note that power cycling will **not** clear the lockout. Successfully unlocking the control will display "Lockout Cleared." Failure to enter the correct PIN will display "Invalid PIN."

In the event that the user-selected PIN is lost or does not clear the Control Lockout, use the Program Button to **Set Factory Defaults**. This will clear the PIN and allow normal operation and selection of a new PIN if desired. See the **Program Button** directions on this page for details.

NOTE: Both the POOL and SPA setpoints will revert back to 65°F (18.5°C) and the POOL and SPA maximum temperature settings will be 104°F (40.0°C). These setpoints will need to be readjusted to desired settings.

NOTE: The LCD temperature display may not agree with the temperature reading of your pool or spa thermometer. The heater reads the water temperature at the inlet. Due to the circulation characteristics of any pool or spa, the water temperature at the inlet to the heater may differ from that observed at a given location in the pool or spa.

STATUS AND DIAGNOSTICS

The digital thermostat models are programmed to display a variety of status and diagnostic messages, depending on the operating conditions.

The following heat status messages are displayed in Pool, Spa, and Remote modes when there are no active fault conditions.

Display	Condition
Heating	Call for heat established, flame present
Spark	Spark operating
No Demand	Heat demand is satisfied

The following conditions are displayed in Pool, Spa and Remote modes.

Display	Condition
Sensor Failure	Thermistor temperatures disagree by more than 2°F
Sensor Open	Thermistor sensor failed open. (Below -20°F)
Sensor Short	Thermistor sensor failed short. (Above 217°F)
Flame w/o CFH	Board is sensing flame when both main and pilot valves are commanded shut.
PV Output Fault	Pilot gas valve output is not in commanded state.
MV Output Fault	Main gas valve output is not in commanded state.
Internal Fault	Board fault, replace board.
EEPROM Fault	Memory fault, reset set points, replace board if fault does not clear.
Clock/Fireman Sw	Time clock/fireman switch circuit is open.
Low Temp Lockout	Water temperature below 36°F.

The following conditions are displayed only while there is a demand for heat present.

Display	Condition
Water Sw Open	Water flow switch open.
Vent/Field Sw #1	Vent spill switch/field switch #1 open.
Hi Limit 1 Fault	High limit 1 open.
Hi Limit 2 Fault	High limit 2 open.
Rollout Sw Open	Rollout switch open.
Flow/Field SW #2	Field-supplied flow switch/field switch #2 open.
Ignition Lockout (Propane Tab Broken)	Alternating with “No pilot sensed” - Pilot flame not established within the required time (15 sec or 90 sec). Alternating with “Main Ign Failure” - Pilot flame lost during the 8 second trial to ignite the main burner.
Ignition Failure (Propane Tab Not Broken)	Alternating with “No pilot sensed” - Pilot flame not established within 90 seconds.
Ign 6min Delay (Propane Tab Not Broken)	Alternating with “Main Ign Failure” - Pilot flame lost 4 times within the 8 second trial to ignite the main burner. Heater will lockout for 6 minutes before retrying.

REMOTE CONTROL INSTALLATION AND OPERATION

CAUTION: Before installing remote controls to the heaters, read the following:

The digital thermostat model is remote-ready in most cases. The digital liquid crystal display (LCD) shows the actual pool temperature, operating status, and service codes (See examples below). The touch pad on the control panel allows you to select the desired pool or spa temperature. It also indicates when a remote system is controlling the heater by displaying **Remote** in the display. When connecting the heater to a remote system, identify whether it is a two- or three-wire remote system. Select the appropriate instruction listed below to properly install the remote to the heater.

Off
Water Temp 69F

Off
No Demand

OFF Mode

Pool Set 65F
Water Temp 60F

Pool Set 65F
Heating

Heating in the POOL Mode

Spa Set 65F
Water Temp 60F

Spa Set 65F
Heating

Heating in the SPA Mode

Remote
Water Temp 69F

Remote
No Demand

Remote Mode

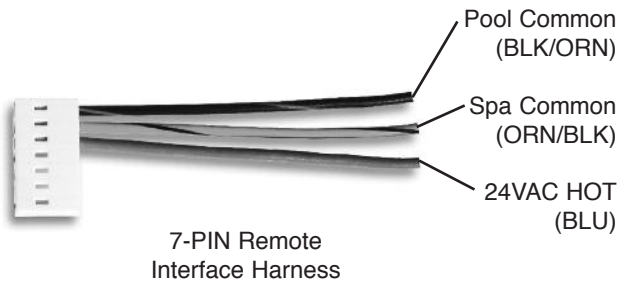

ACTIVATING THE REMOTE

To activate or deactivate the remote function, follow these steps:

Press and hold the UP and DOWN arrow buttons for 3 to 5 seconds.

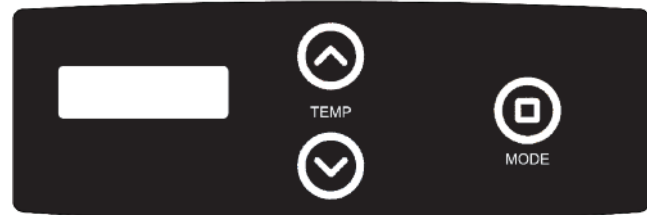

The second line of the display will alternate even when the unit is off (“No Demand”).

Remote Pool 65F
Water Temp 60F

Remote Pool 65F
Heating

Remote Spa 65F
Water Temp 60F

Remote Spa 65F
Heating

REMOTE OPERATION

The heater is equipped with the ability to work with external remote controls. The supplied 7-pin remote wiring connector supplies power out to either a toggle switch or the switch contacts of a third party remote. The remote works by either making or breaking the circuit created by the remote wiring. Typically, a remote does not supply power to the heater, it only provides a switching function to turn the heater On or Off. **If your remote is supplying its own voltage to the heater, it will not work with this heater and may damage the digital circuit board.**

For operation of the heater using the onboard thermostatic controls with a time clock, see the “Time Clock / Fireman’s Switch” section.

NOTE: When in remote operation, the keypad mode and temp buttons are disabled.



Note: Electrostatic Discharge (ESD) damage can be caused by direct or indirect contact with the wiring or circuit board. When one walks to the heater area, an electrostatic charge accumulates on the body. Contact of a finger allows the body to discharge, possibly causing device damage. This damage can be limited if the service person discharges himself, following ESD preventive/removal practices, and holds on to the heater enclosure for 5 seconds before proceeding.

REMOTE CONTROL WIRING

Important Installation Notes for Remote or External Wiring Configuration

- Remote wiring must be run in a separate conduit.
- Remote wiring must not be run parallel to high voltage lines.
- For runs of under 30 feet, remote wiring should have stranded conductors with a minimum of 22 AWG, 600V, cable twisting 1.5 to 2.5 in. lay and jacketed.
- For runs over 30 feet, the conductors should be a minimum of 20 AWG, 600V, cable twisting 1.5 to 2.5 inch lay that is shielded and jacketed.
- Maximum cable length is 200 feet.
- For both two- and three-wire remote systems, the provided 7-pin wiring connector must be utilized. Please refer to the wiring instructions.

NOTE: The remote wires must be connected to the 7-pin connector **before** the connector is plugged into the board.

2-Wire Remote Control (On-Off)

This application assumes that only one heating function (pool or spa) is required.

1. Turn on power to the heater.
2. For a 2-Wire Remote Control from a remote without its own sensor, push the mode button to the "POOL" or "SPA" mode and set the desired setpoint (eg. 102 °F for Spa).
3. For a 2-Wire Remote Control from a remote with its own sensor, push the mode button "POOL" or "SPA" mode and set the temperature to the highest setting available on the control. The actual setpoint will be controlled by the remote control.
4. Turn the mode button to "OFF" and remove power from the heater.
5. On the "Remote Interface Harness", connect the BLUE wire to one side of the "REMOTE" switch and connect the other side to either the ORANGE/BLACK wire for "SPA" operation or the BLACK/ORANGE wire for "POOL" operation.
6. Attach wire nut on unused wire to the "Remote Interface Harness."
7. Install the "7-Pin Remote Interface Harness" to the P8 connector and turn power "On" to the heater.

To activate the remote control, see page 30.

3-Wire Remote Control Using Three-Position Switch (Pool-Off-Spa, or Low-Off-High)

This application assumes that both heating functions (pool and spa) are required.

1. Turn on power to the heater.
2. Push the mode button to the "POOL" or "SPA" mode and set the desired temperature for each (eg. 80°F for Pool and 102°F for Spa).
3. Turn the mode button to "OFF" and remove power from the heater.
4. On the "Remote Interface Harness" connect the BLUE wire to one side of the "REMOTE" switch and connect the ORANGE/BLACK wire for "SPA" operation and the BLACK/ORANGE wire for the "POOL" operation.
5. Install the "Remote Interface Harness" to the P8 connector and turn power "ON" to the heater.

To activate the remote control, see page 30.

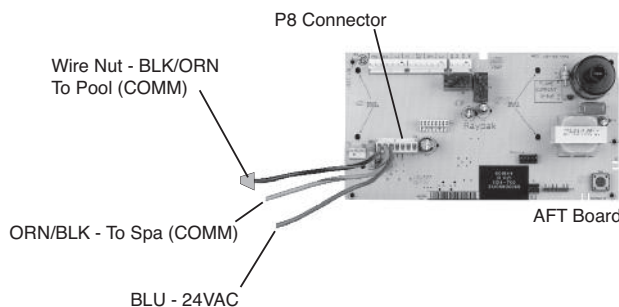

2-Wire Remote Control

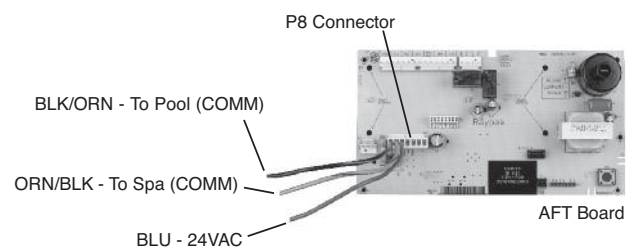

3-Wire Remote Control

TIME CLOCK/FIREMAN'S SWITCH

To operate the heater with a time clock, connect the timer to the fireman's switch connection in the heater's wiring. The time clock should be of the dual switch type and set to shut off the call for heat to the pool heater 15 to 20 minutes prior to shutting down the pool pump. The fireman's switch connection is located on the 14-pin header connected to the digital control board. Splice into the red wire jumper tagged "Where necessary add "Fireman's" switch circuit here" to connect the time clock. **The fireman's switch connection must be a dry contact and must not supply power to the heater. Powering the fireman's switch connection externally may damage the heater, and is not covered by warranty.**

Do not exceed 50ft of total wiring using 18 AWG stranded copper wire rated for 105°C (221°F) minimum.

NOTE: *When using a time clock, the heater will display "Clock/ Fireman Sw" when the fireman's switch is open, indicating that the time clock has shut off the call for heat.*

WATER FLOW SWITCH

The water flow switch ensures that the heater operates only when the filter pump is in operation. It is located on the outlet side of the In/Out header. It is factory pre-wired and pre-set with a minimum water flow paddle. Install conduit to the upper jacket hole. Connect two wires from the conduit to the appropriate terminal wires behind the transformer cover (i.e. orange to orange and orange/black to orange/black). No further adjustment is needed.

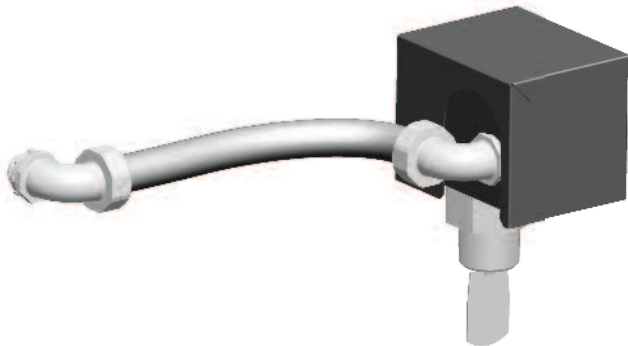

NOTE: *The sheet metal cover should be in place at all times to protect the flow switch from rain and other environmental factors.*

CAUTION: *Do not operate the heater without the function of a properly adjusted flow switch.*

FLAME ROLL-OUT SAFETY SWITCH

The heater is equipped with a thermal cutoff device to prevent flame roll-out in the event the heat exchanger becomes blocked. This is a "single-use" type fusible link or thermal fuse, that must be replaced when disabled by an over-temperature condition, caused by excessive restriction in the heat exchanger flue passage.



HIGH LIMITS

The heater is equipped with two automatic high limits. One is located in the inlet/outlet header, and the other is located in the return header. Both are set to open at 135°F.

NOTE: *An erratic high limit is often characteristic of an internal heat exchanger problem, e.g. scale build-up, defective bypass. Refer to Troubleshooting section (on page 36).*



HIGH LIMIT REMOVAL

1. Shut off main electrical power switch to heater.
2. Remove inlet/outlet and/or return inspection panel.
3. Remove defective high limit and replace with a new high limit.
4. Replace inspection panel.

PILOT SAFETY

The heater employs a pilot safety which closes the main gas valve within 8/10ths of a second whenever the pilot flame is interrupted. The pilot flame is automatically lit when the device is powered. The heater performs its own safety check and opens the main valve only after the pilot is proven to be lit.

BURNER TRAY REMOVAL

1. Shut off main electrical power switch to heater.
2. Shut off gas upstream of heater.
3. Remove front door.
4. Disconnect gas line from gas valve.
5. Remove (2) screws that mount burner tray to unit, and (2) screws that secure gas valve to jacket.
6. Disconnect wires that terminate at gas valve.
7. Disconnect hi-tension wire from PC board.
8. Slide out burner tray.
9. Reverse above procedure to reinstall.

GAS VALVE REMOVAL

1. Shut off gas supply to the heater. Remove gas piping to gas valve inlet.
2. Disconnect wires, pilot tubing and bleed line, if required.
3. Remove burner tray from heater.
4. Turn vertical gas pipe from manifold slightly and unscrew gas valve.
5. Reverse above procedure to reinstall.

MAIN BURNER AND ORIFICE REMOVAL

1. Remove burner tray.
2. Remove screws and burner hold-down bracket.

NOTE: *If the heat exchanger is sooted badly, the burner hold-down bracket and spacer can become distorted from direct-flame impingement and this usually necessitates replacement of these parts.*

3. Lift burners from slotted spacers and slide from orifices. Clean with a wire brush.
4. Orifices usually do not need to be replaced. To clean, run either copper wire or wood toothpick through orifice. **Do not enlarge hole.** To remove orifice, use a socket wrench and remove from manifold. **DO NOT** overtighten when reinstalling.

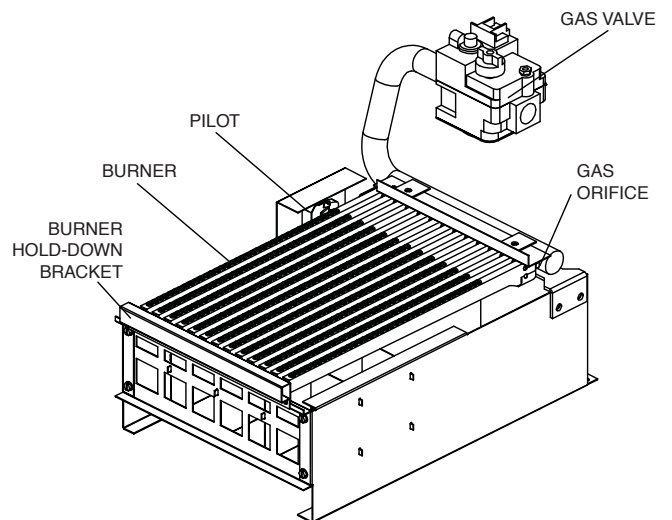

PILOT REMOVAL AND CLEANING

1. Disconnect pilot tubing and wires from gas valve.
2. Remove pilot assembly from burner tray.
3. Remove pilot from bracket.
4. Remove pilot orifice and air opening, and clean with wire or small brush.

CAUTION! Do not enlarge hole in pilot orifice.

5. Reverse above procedure to reinstall.

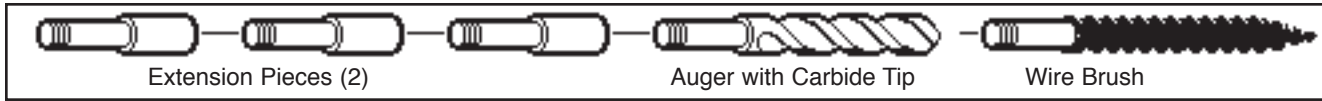

HEAT EXCHANGER REMOVAL

1. Shut water, gas and electricity off, close valves and relieve pressure, then remove relief valve. Remove side inspection panels.
2. Remove top jacket holding screws.
3. Remove rear top panel.
4. Remove screws mounting the rain shield to the rear panel. Also remove the screws that mount the rain shield to the sway brace. Remove rain shield.
5. Remove the four (4) screws holding down the flue collector. Remove the flue collector.
6. Disconnect flange nuts on Inlet/Outlet header, loosen union(s) at gas pipe and slide heater away from piping.
7. Lift heat exchanger straight up using caution not to damage refractory.
8. Reverse above procedure to reinstall. Make sure the insulation strips are properly replaced on top of the refractory retainer.

1. Remove top and flue collector from cabinet.
2. Remove "V" baffles from heat exchanger.
3. Remove burner tray. (See page 33).
4. Remove heat exchanger from the heater and wash with a garden hose, making sure soot is removed from spaces between fins.
5. Reverse above procedure to reinstall.

NOTE: In extreme cases it may be necessary to do steam cleaning at the local car wash. **DO NOT WIRE BRUSH.**

COMBUSTION CHAMBER REMOVAL

To remove combustion chamber, you must first have removed the heat exchanger.

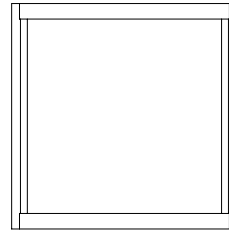

REFRACTORY PANELS - TOP VIEW

TUBE CLEANING PROCEDURE

Establish a regular inspection schedule, the frequency depending on the local water conditions and the severity of service. Do not let the tubes clog up solidly. Clean out deposits over 1/16" in thickness.

The heater may be cleaned from the return header side, without breaking pipe connections. It is preferable, however, to remove both headers for better visibility through the tubes and to be sure the ground-up lime dust does not get into the system.

Note that you do not remove the top panel or the heater exchanger, generally.

After reaming, mount the wire brush in place of the auger and clean out debris remaining in the tubes.

Another method is to remove the heat exchanger, ream tubes and immerse heat exchanger in non-inhibited de-scale solvent for severe scale build-up.

DESOOTING PROCEDURE

WARNING: SOOT IS COMBUSTIBLE. EXERCISE EXTREME CARE.

Soot will clog areas between fins and cause eventual tube failure. Any sign of soot at the base of the burners or around the outer jacket indicates a need for cleaning.

IMMERSION WELL REPLACEMENT

1. Shut off water to heater and drain heat exchanger.
2. Remove access panel on water connection side.
3. Remove old immersion well with bushing and sleeve.
4. Install replacement well in header.

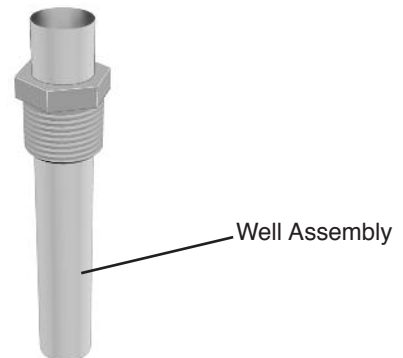

UNITHERM GOVERNOR (U.G.) REPLACEMENT

1. Shut water, gas and electricity off, close valves and relieve pressure.
2. Drain heat exchanger.
3. Remove retainer plug located next to the outlet pipe connection.
4. Unsnap old U.G. to remove from retainer plug. Snap in new U.G.
5. Reinstall retainer plug, taking care to lubricate gasket with a non-petroleum based grease such as AquaLube.

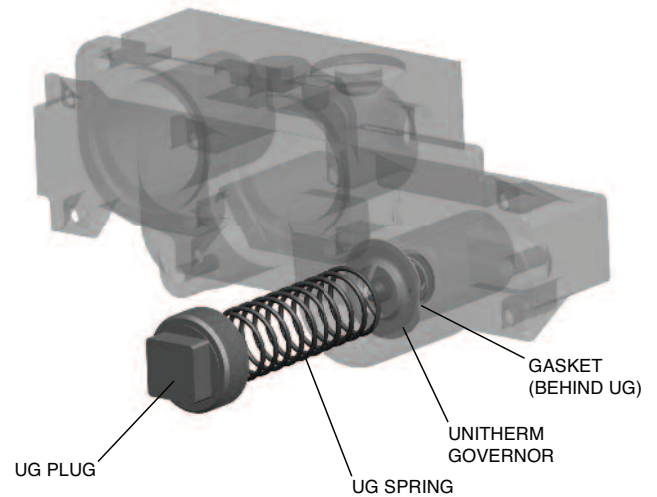

To test the operation of the Unitherm Governor, place in hot water (over 110°F) and watch for movement against spring. If there is no movement, replace unit.

SECTION 5 - TROUBLESHOOTING

MECHANICAL

IMPORTANT NOTICE These instructions are intended for the use of qualified personnel who are specifically trained and experienced in the installation of this type of heating equipment and related system components. Installation and service personnel may be required by some states to be licensed. Persons not qualified shall not attempt to install this equipment nor attempt repairs according to these instructions.

<u>PROBLEM</u>	<u>CAUSE</u>	<u>SOLUTION</u>
Harmonics, or whining noise	U.G. inoperative..... *Debris or restriction in system..... *Debris in gas line..... Low flow.....	Check movement by putting in hot water (110°F or higher). If no movement, replace. Locate the restriction and remove. Flush system and clean. Remove debris or blow out gas line. Scale forming in heat exchanger - clean heat exchanger and check pool pH and total alkalinity.
Heater going on and off continuously	Dirty filter..... Low water level in pool..... External bypass setting out of adjustment..... Marginal flow.....	Clean or replace filter. Raise water level. Adjust bypass. Check pump. Check flow switch.
Liming or scale forming in exchanger	Pool water..... Bypassing too much water..... U.G. not functioning.....	See Water Chemistry on page 2. Inspect bypass for movement, if no movement, replace. Replace if no movement when heated.
Sooting	High flow rates..... U.G. Inoperative..... *Air starvation..... *Improper venting..... *Insects or debris clogging burner intake ports.....	Reduce by adding manual bypass valve. Adjust manual bypass valve until heater outlet water temperature is between 105°F and 110°F. Check movement by putting in hot water (110°F or higher). If no movement, replace. Refer to installation instructions. Follow recommended installation instructions. Clean burners.
Pilot outage or "Weak Flame" signal	Low gas pressure..... Restricted/dirty pilot..... Weak pilot generator.....	Adjust gas pressure. Clean pilot and/or electrode. Replace pilot.
Yellow lazy flame	Low gas pressure..... *Insects or debris clogging burner intake ports.....	Adjust gas pressure. Clean burners.
Outer jacket very hot (paint blistered)	*Broken refractory caused by shipping damage or improper combustion..... Excessive sooting of heat exchanger..	Replace refractory panels. Determine cause of sooting & correct.
Takes too long to heat pool or spa	Under-sized heater..... Filter not running long enough..... Dirty filter..... Gas line or meter undersized.....	Calculate heating capacity of heater: $\frac{\text{Htr. output(BTUH)}}{\text{Pool gallonage} \times 8.33}$ or refer to heater sizing chart. This does not take into account heat loss due to weather. Reset time clock. Clean filter. Refer to installation instructions.
Leaking at well	Overacid.....	Replace well and maintain proper water chemistry.
Leaking at heat exchanger	Overacid.....	Replace heat exchanger and maintain proper water chemistry.
Gasket brittle and leaking - (overheated)	Refractory damage..... Sooted heater.....	Replace refractory. Determine cause of sooting and correct.

* Indicates symptom which usually occurs on initial start-up.

CONTROL LOGIC - FLOW CHART

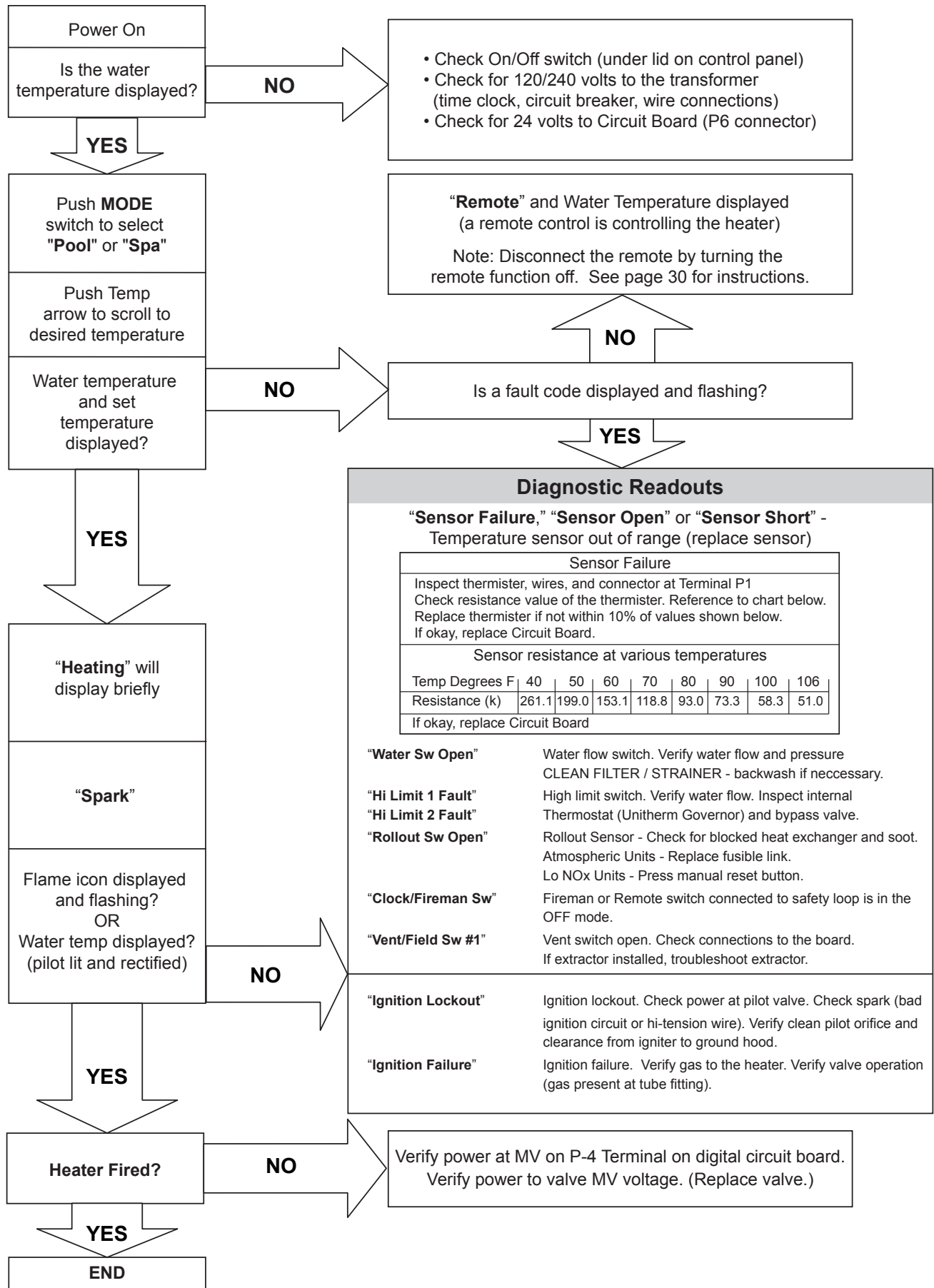

SECTION 6 - REPLACEMENT PARTS

NOTE: To supply you with the correct part, it is important that you supply the heater model number, serial number and type of gas when applicable.

Any part returned for replacement under standard company warranties must be properly tagged with a return parts tag, completely filled in with the heater serial number, model number, etc., and shipped to the Company freight prepaid.

If determined defective by the Company and within warranty, a like part or equal substitution will be returned, freight collect. Credit will not be issued.

MANUFACTURER:

2151 EASTMAN AVENUE
OXNARD, CA 93030

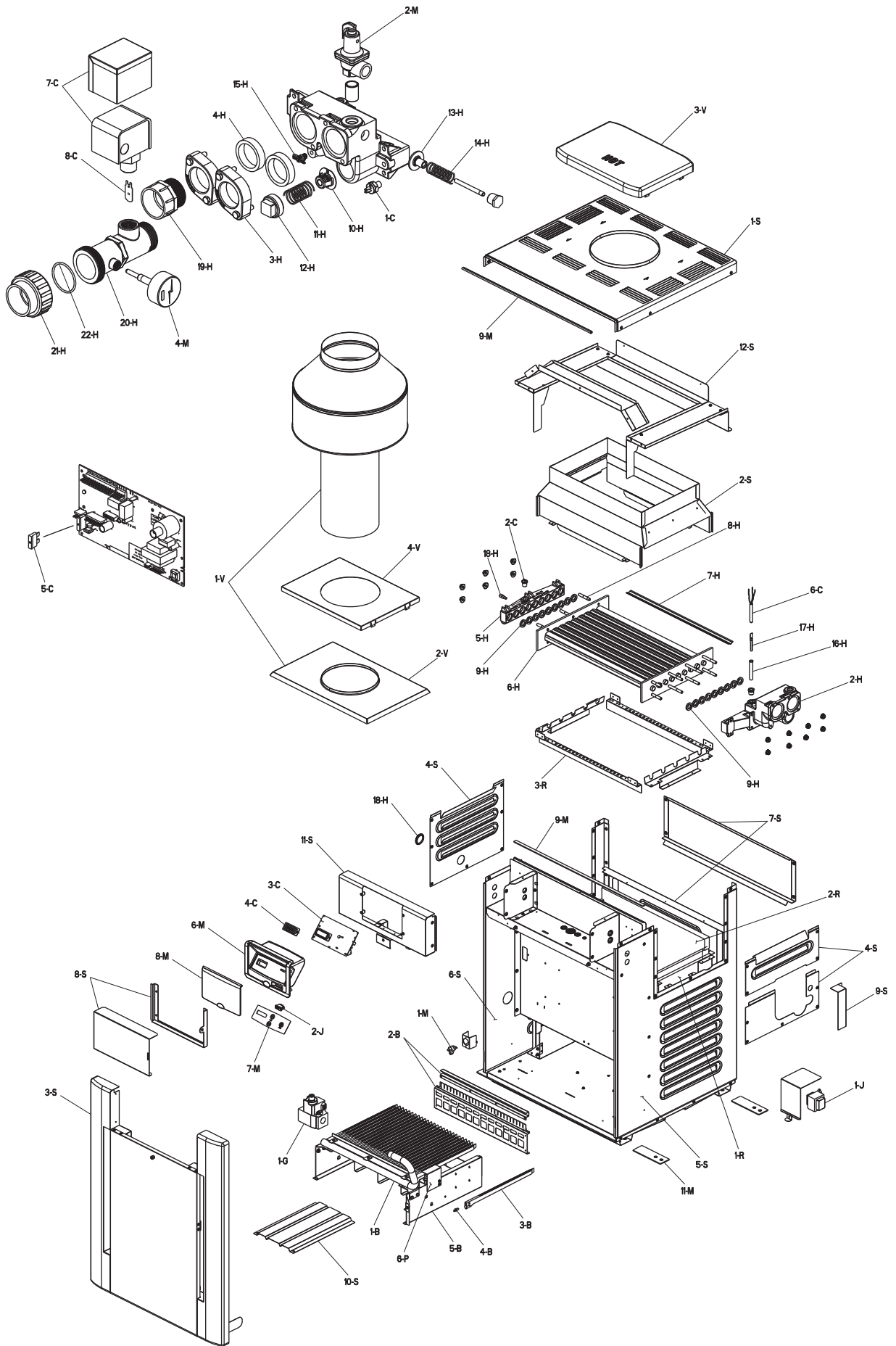

CALL OUT	DESCRIPTION	268	408
B	BURNER TRAY		
1-B	Burner Tray w/Burners (sea level)*	013796F	013797F
	Burner Tray w/o Burners (sea level)*	013798F	013799F
	Burner Tray w/Gas Valve Nat	013800F	013801F
	Burner Tray w/Gas Valve Pro	013802F	013803F
2-B	Burner Spacer/Hold Down Kit	013804F	013805F
3-B	Burner	301210/18	301210/27
4-B	Burner Orifice Nat. #50 (Sea Level)*	350079F/18	350079F/27
	Burner Orifice Pro. #57 (Sea Level)*	350083F/18	350083F/27
5-B	Burner Tray w/o Manifold w/o burners	013806F	013807F
C	CONTROLS		
1-C	AGS 135° (Auto Gas Shut-Off) - Red Epoxy	600892B	600892B
2-C	High Limit 140° - Black Epoxy	600893B	600893B
3-C	P. C. Board/Control	013464F	013464F
4-C	LCD Display	013640F	013640F
5-C	Fuse 5 AMP	013733F	013733F
6-C	Temperature Sensor IID Units	009577F	009577F
7-C	Flow Switch	007142F	007142F
8-C	Flow Switch Paddle	010026F	010026F
G	GAS VALVE		
1-G	Combination Valve - Nat.	003900F	003900F
	Combination Valve - Pro.	004306F	004306F
H	HEAT EXCHANGER		
1-H	Heat Exchange Assy.Cupro Nickel ASME BR	013808F	013809F
2-H	Inlet/Outlet Header ASME BR Complete	013810F	013810F
	Inlet/Outlet Header ASME BR	013811F	013811F
3-H	Inlet & Outlet Flange BR	013812F	013812F
4-H	Flange Gasket	800080B	800080B
5-H	Return Header ASME BR	002451F	002451F
6-H	Tube Bundle Cupro Nickel ASME **	013813F	013814F
7-H	Baffle	013815F	013816F
8-H	Stud Bolt Kit	007870F	007870F
9-H	Header Gasket (9)	800014B	800014B
10-H	Unitherm Governor	062234B	062234B
11-H	U.G. Retainer Spring	013792F	013792F
12-H	U.G. Plug	013738F	013738F
13-H	Bypass Valve	062235B	062235B
14-H	Bypass Spring	013794F	013794F
15-H	Drain Valve	013793F	013793F
16-H	Sensor Well	003765F	003765F
17-H	Well Retaining Clip	300203	300203
18-H	Rear Drain Plug & Cover	005264F	005264F
19-H	2" CPVC Adapter (Inlet Plumbing)	005393F	005393F
20-H	2" CPVC Connector (Outlet Plumbing)	013795F	013795F
21-H	2" CPVC Connector & Nut	006723F	006723F
22-H	O Ring	006724F	006724F
J	CONTROL BOX		
1-J	Transformer 120/240/24V	006736F	006736F
2-J	Rocker Switch	009493F	009493F

*FOR INSTALLATION AT OVER 2,000 FEET ABOVE SEA LEVEL, DERATE 4% PER 1,000 FEET ABOVE SEA LEVEL.

**WARNING: The Hydraulic conditions or water chemistry that caused the tube bundle to fail have very likely also damaged the bypass valve and Unitherm Governor. We recommend you replace the Unitherm Governor and inspect the bypass assembly. Failure to do so could cause premature failure of this replacement part.

CALL OUT	DESCRIPTION	268	408
M	MISCELLANEOUS COMPONENTS		
1-M	Thermal Fuse	005899F	005899F
2-M	PRV 125 PSI	007224F	007224F
3-M	Deliming Kit	052871F	052871F
4-M	T & P Gauge	007399F	007399F
5-M	Wire/Harness	013817F	013817F
6-M	Control Bezel (Includes Switch Decal)	013491F	013491F
7-M	Switch/Decal-Membrane	013492F	013492F
8-M	Control Bezel Cover	009487F	009487F
9-M	Gasket Insulation (Swaybrace & Jacket Top)	010350F	010350F
10-M	Touch-up Paint (Charcoal Gray)	750256	750256
11-M	Tie Down Bracket (Optional)	011636	011636
P	PILOT		
1-P	Pilot Nat & Pro	002003F	002003F
2-P	Pilot Orifice Nat .020	003903F	003903F
	Pilot Orifice Pro .012	004308F	004308F
3-P	Pilot Mounting Bracket	013791F	013791F
4-P	Pilot Tube	004078F	004078F
5-P	Hi Tension Wire with Pilot Electrode	007864F	007864F
6-P	Pilot Shield	010351F	010351F
R	REFRACTORY		
1-R	Refractory Common (Left & Right)	010088F	010088F
2-R	Refractory Uncommon (Front & Rear)	010090F	010092F
3-R	Refractory Retainer Kit	010388F	010390F
S	SHEETMETAL		
1-S	Jacket Top (Louvered)	010048F	010050F
2-S	Flue Collector	013818F	013819F
3-S	Door Assy	013820F	013821F
4-S	Access Panel Set (3 Pcs)	010312F	010312F
5-S	Jacket Side Panel Right	010376F	010376F
6-S	Jacket Side Panel Left	010377F	010377F
7-S	Jacket Rear Panel (2 Pcs.)	010373F	010375F
8-S	Control Cover/Lock Box	009505	009505
9-S	High Limit Cover	010319F	010319F
10-S	Base Heat Shield	010320F	010320F
11-S	Up Front Control Panel	013822F	013823F
12-S	Weather Shield	013824F	013825F
V	VENTING		
1-V	Indoor Stack Kit (Includes inner adapter panel)	009839	009841
	Outdoor Stack Kit (Includes inner adapter panel)	009835	009837
2-V	Stack Adapter	010331F	010333F
4-V	Outer Stack Adapter	011462F	011464F
3-V	"Pagoda" Top	010335	010337
Atmospheric CONVERSION KITS*		268	408
	Nat. to Pro.	**	**
	Pro. to Nat.	**	**

* Gas conversions are to be done only by a qualified agency.

** Conversion must be made with complete burner tray with gas valve (see item 1-B).



www.raypak.com

Raypak, Inc., 2151 Eastman Avenue, Oxnard, CA 93030 (805) 278-5300 Fax (805) 278-5468
Litho in U.S.A.