

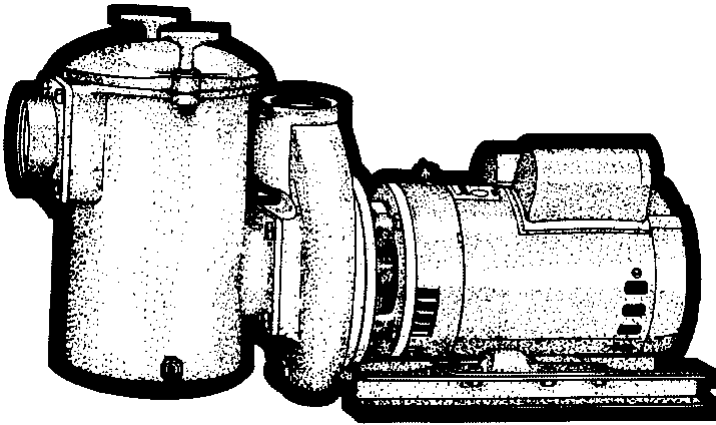

aqua flo

OWNER'S MANUAL

"AC" SERIES PUMPS



IMPORTANT SAFETY INSTRUCTIONS

When installing and using this electrical equipment, basic safety precautions should always be followed, including the following:

1. **READ AND FOLLOW ALL INSTRUCTIONS.**

2. **WARNING** - To reduce the risk of injury, do not permit children to use this product unless they are closely supervised at all times.

3. **CAUTION** - This pump is for use with permanently installed pools and may also be used with hot tubs and spas if

so marked. Do not use with storable pools. A permanently installed pool is constructed in or on the ground or in a building such that it cannot be readily disassembled for storage. A storage pool is constructed so that it may be readily disassembled for storage and reassembled to its original integrity and has a maximum wall height of 42 inches (1.07m).

4. Do not install within an outer enclosure or beneath the skirt of a hot tub or spa unless so marked.

5. **SAVE THESE INSTRUCTIONS.**

INSTALLATION & OPERATING INSTRUCTIONS

GENERAL

Your AQUA-FLO pump has been quality built and engineered to give maximum efficiency under normal water pumping conditions. Consult the manufacturer for any other applications.

LOCATION OF PUMP

For best pump performance, locate the system as close to the water source as possible. Provide adequate access around the pump for inspection and maintenance. Place pump on a firm level surface. Pump need not be bolted down unless required by local code.

PUMP CONNECTIONS

Suction line from pool (skimmer and main drain) must be connected to inlet at Hair and Lint Trap. Discharge line to pool (return lines) must be connected to Outlet at top of pump via filter. If pump is installed below water level of pool, install valves on the inlet and outlet piping to permit removing of equipment without draining the pool.

CAUTION: During the pressure test procedure, this pump is under pressure. DO NOT LOOSEN lock handles while pump is running or until all pressure is released. Tighten lock handles securely by hand only. Raise pressure slowly. Do not exceed 50 psi. Extreme care must be taken during pressure test. Failure to follow these instructions explicitly can result in personal injury.

PRIMING PUMP

At initial start-up, pump must be primed by filling hair and lint trap with water. To prime pump, remove cover from hair and lint trap: fill pump and suction trap with water. Replace cover (make sure the o-ring is in place) and tighten lock handles. Pump will now prime, with priming time depending upon lift and horizontal distance of suction piping.

CLEANING BASKET

It is important to clean the hair and lint basket frequently. A dirty basket will reduce the efficiency of the filter and heater and will put an abnormal stress on the pump motor which could result in costly repair bills.

CAUTION: Do not remove hair and lint strainer lid while pump is running or under pressure! Lid is held in place by lock handles which can be removed or tightened by hand. Basket must be kept clear of leaves and debris at all times.

REMOVING BASKET

1.) Turn off motor. 2.) Remove lid. 3.) Remove basket and empty debris. 4.) Replace basket, fill with water, replace lid securely to prevent air from entering and tighten.

WARNING - All electrical wiring of the motor installation must be done by a qualified electrician in accordance with applicable electrical codes. Before working on any motor, be certain that the source of electrical power is off at the main junction box.

BONDING WIRE - Upon installation of the pump, the motor must be bonded with a No. 8 AWG solid copper conductor per National Electrical Code. The connection should be from the accessible wire connector on the motor to all metal parts of the swimming pool, spa or hot tub structure and to all electrical equipment, metal conduit, and metal piping within 6 feet (1.5 m) of the inside walls of a swimming pool, spa or hot tub, when the motor is installed within 5 feet of the inside walls of the swimming pool, spa, or hot tub.

NOTE: For electrical connections, see wiring diagram on motor rating plate.

DO NOT USE TOOLS. 5.) Turn on motor. 6.) Open air-relief valve on top of filter until steady stream of water comes out.

NOTE: If pump is installed below water level of pool, close return and suction lines prior to opening hair and lint pot. Make sure to re-open valves prior to operating.

DO NOT RUN PUMP DRY!

Always maintain proper water level in pool. If water level falls below skimmer intake, pump will suck air. Pump is equipped with a maintenance-free, heavy-duty mechanical seal. Damage will occur if pump runs dry, and warranty will be voided.

TO PREVENT FREEZING

Drain liquid from pump through plug at bottom section of volute. It is recommended to apply a good rust inhibitor into liquid end to prevent corrosion. Be sure motor is kept dry and covered. In mild climate area, when freezing may occur, run pump and filter equipment continuously to prevent freezing.

MOTOR

Your pump is equipped with a permanently lubricated, maintenance-free, heavy-duty industrial quality motor especially designed to withstand the heavy-duty requirements of swimming pool application. Wiring connection must agree with incoming line voltage. Improper wiring can cause serious injuries and damage to the motor, voiding warranty.

NOTE: Your motor is designed to withstand the effects of normal rainfall. To increase the life of your motor, observe the following:

- 1.) Do not flood motor or submerge in water. To do so voids warranty.
- 2.) Provide ample cross ventilation, minimum of 6" at all points.
- 3.) Keep motor and surrounding area clean.
- 4.) Avoid sweeping or stirring dust near motor while it is running.
- 5.) Avoid storing or spilling dry chemicals, powders, etc., near motor.
- 6.) Provide protection against the elements.
- 7.) Locate motor on a slight elevation so water will drain away from motor.
- 8.) Avoid spilling or dripping liquid chemical on or near motor.
- 9.) Avoid splashing water or hosing deck near motor. Water damage voids warranty.

For replacements, contact your local supplier or authorized service man.

TROUBLE SHOOTING

If pump loses prime, or if too many bubbles come through return line, check:

- 1.) Hair and lint pot cover is tight and o-ring is in place and free from defects.
- 2.) Valves on suction and return lines are working properly and open.
- 3.) Water level in pool is too low.
- 4.) Filter o-ring or gasket is in place and free from defects.
- 5.) All fittings and connections are secure and air tight.

Not pumping water, check:

- 1.) Filter pressure gauge reading too high, indicating filter needs cleaning.
- 2.) Clogged plumbing lines.
- 3.) Impeller adjustment incorrect. Adjust impeller .015 inches from face of volute.
- 4.) Worn or damaged impeller.

Motor does not run, check:

- 1.) Circuit breakers.
- 2.) Incorrect or loose wire connections.

- 3.) Thermal protector in motor tripped. Allow motor to cool, then try to restart.

Motor makes humming noise but won't start, check:

- 1.) Make sure motor shaft turns free.
- 2.) Jammed impeller or an obstruction in (volute) casing.
- 3.) Low voltage and undersized wire.

Motor overheating and cycling on and off, check:

- 1.) Incorrect or loose wire connections.
- 2.) Low voltage supply (frequently caused by undersized wire.)
- 3.) Make sure the motor gets a fresh air supply and the vents are kept unclogged.

Noises, check:

- 1.) Plumbing vibration.
- 2.) Impeller turns freely and is properly adjusted.
- 3.) Motor bearings.
- 4.) For cavitation, due to obstruction in or undersized suction line.

"AC" SERIES REPLACEMENT PARTS

REF. NO.	PART NO.	DESCRIPTION
1	93497000	Motor, 3 HP Comm, Single Phase
1	93497010	Motor, 3 HP Comm, Three Phase
1	93498000	Motor, 5 HP Comm, Single Phase
1	93498300	Motor, 5 HP Comm, Three Phase
2	91140000	Bracket, 3 & 5 HP
3	99050050	Bolt, Hex Machine, 3/8"-16 x 5/8"
4	99050000	Bolt, Hex Machine, 3/8"-16 x 3/4"
5	91500000	Gasket, Volute
6	92500000	Seal, Replacement
7	91690002	Impeller, 3.0 HP, High Head
7	91690051	Impeller, 3.0 HP, Medium Head
7	91690102	Impeller, 5.0 HP, High Head
8	99890160	Washer, Flat, 5/16" x .096"
8A	99050030	Bolt, Hex Machine, 5/16"-18 x 5/8"
9	92770000	Volute
10	92290000	Plug, Pipe
11	91500200	Gasket, Trap, 6" and 8"

REF. NO.	PART NO.	DESCRIPTION
12	92620100	Trap, 6" x 2"
12	92620150	Trap, 8"
13	91450000	Flange, Suction, 2-1/2"
13	91450010	Flange, Suction, 3"
14	91110010	Basket, Strainer, 6"
14	91110050	Basket, Strainer, 8", Stainless Steel
15	92200010	O'Ring, Trap Cover, 6"
15	92200020	O'Ring, Trap Cover, 8"
16	91230050	Cover, Trap, 6"
16	91230100	Cover, Trap, 8"
17	91920001	Lockhandle
18	91100000	Pump Base
19	99890050	Washer, 5/16, SS
20	99560000	Nut, Hex, 5/16-18, SS
Q	91040030	Assembly, Trap Complete 6" x 2"
Q	91040040	Assembly, Trap Complete 8" x 2-1/2"
Q	91040050	Assembly, Trap Complete 8" x 3"

Q Includes Ref. #'s 11-17 & 3

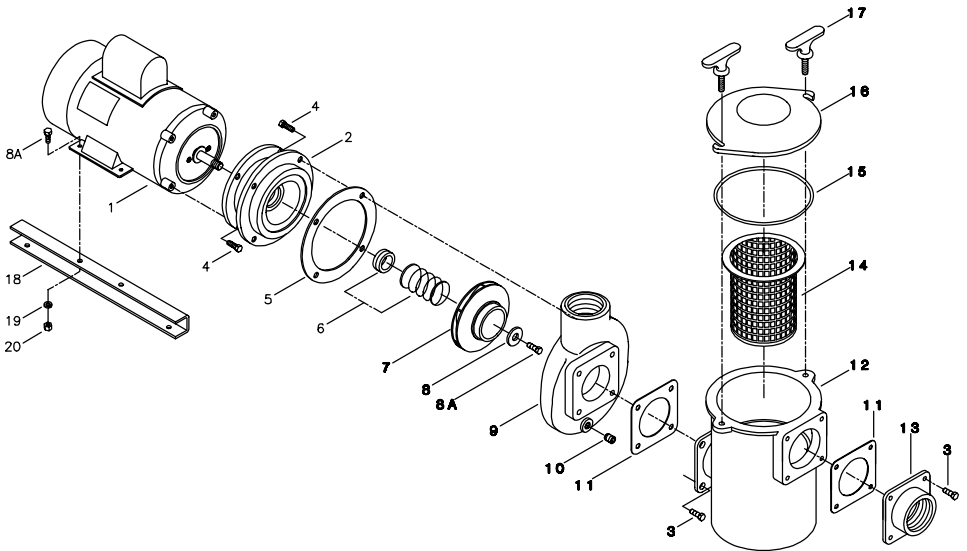

"AC" SERIES PUMPS LIMITED WARRANTY

Aqua-Flo, Inc.

WARRANTS TO:

the original retail purchaser only, that the products Aqua-Flo manufactures are free from defects in material and/or workmanship for a period of five years from date of purchase, not to exceed six years from date of manufacture, (pump seals warranty for 30 days). If within the first two years from date of manufacture, any such product proves to be defective, it shall be repaired or replaced at AQUA-FLO'S option as follows:

The original retail purchaser shall first contact the installing dealer, as soon as possible after discovery of the defect, but in no event later than the expiration date of this warranty. Or upon notification,

AQUA-FLO, INC.

Customer Service Department
P.O. Box 2526, Chino, CA 91708

will advise the consumer of the address to which the defective item may be shipped, together with the model number, serial number and date of purchase of item claimed to be defective. The consumer must pay for all shipping charges.

If within the years three through five any such products shall prove defective, the original retail purchaser shall be entitled to purchase replacement equipment or components at the following percentage off the current published list price:

Third year	60%
Fourth year	40%
Fifth year	20%

EXCLUSIONS

1. This warranty shall not apply to any failures resulting from negligence, abuse, misuse, misapplication, improper installation, alteration or modification, chemical corrosion, or improper maintenance.
2. Any items manufactured by other companies and used by AQUA-FLO in its products may carry warranties by the original manufacturers.
3. AQUA-FLO is not liable for incidental or consequential damages, loss of time, inconvenience, incidental expenses, labor or material charges in connection with removal or replacement of the equipment.

AQUA-FLO is not responsible for any implied warranties or representations by others, and the foregoing warranty is exclusive and in lieu of all warranties provided herein.

Some states do not allow the exclusion or limitation of incidental or consequential damages, so the above limitation or exclusion may not apply to you.

This warranty gives you specific legal rights, and you may also have other rights which vary from state to state.

The logo for Aqua Flo, Inc. features the words "aqua flo" in a bold, lowercase, sans-serif font. The letter "a" is significantly larger than the other letters. A stylized, wavy line representing water is positioned beneath the "a" and extends slightly to the right, underlining the "a" and partially the "q".

AQUA-FLO, INC.

P.O. Box 2526 • Chino, California 91708

Shipping: 5651 Schaefer Avenue • Chino, California 91710

909/591-7453 • FAX 909/627-5660